

H series 1.2 / 1.4 / 1.6 t Electric Reach Truck

The New H series Electric Reach Truck, 1.2-1.6 ton, apart from its excellent performance, is also very economical. The reach trucks are used wherever space is confined and where heavy loads are to be raised to high lift heights.

1) The drive's compartment, through generous dimensioning, provides the driver with a comfortable body position. The excellent all-around visibility and the low noise level add to the ease of working.

2) The operator compartment incorporates controls for hydraulic functions, direction control, horn, lights and handbrake, all within convenient reach of the operator. Padded armrest, rubber floor mat and resin coated control knobs ensure comfort for daylong operation. The tilt of the steering column can be freely adjusted to any degree.

3) Curtis made Multi-function instrument, together with the multi display monitor provide information and function input to the operator to allow optimum performance and operator confidence.

4) Drive and hydraulic control fitted as standard. MOSFET CHOPPER, Power transistors with high impulse frequencies control the motors in an energy saving and noiseless manner. The drive control permits jerk-free starting and a strong acceleration. Adjustable energy feedback on releasing the drive pedal through regenerative braking.

5) The chassis design and steering geometry provide an outstanding turning radius of 1675mm and reach stroke of 602mm (1.4 ton model). The steering angle of 90° in each direction further enhances maneuverability. These specifications ensure improved safety clearances in confined spaced with high loading.

6) Low noise, less pollution and energy saving, these features all satisfied with environment protection.

7) Drive and electronics cover may be opened quickly and easily for servicing and maintenance work. The service access door on the truck provides excellent access to the major service components. All motors, drive gearbox, pumps, brakes and steering are easily accessible.

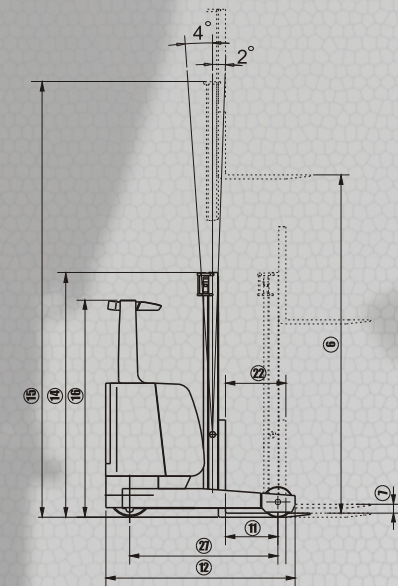

DIMENSIONS

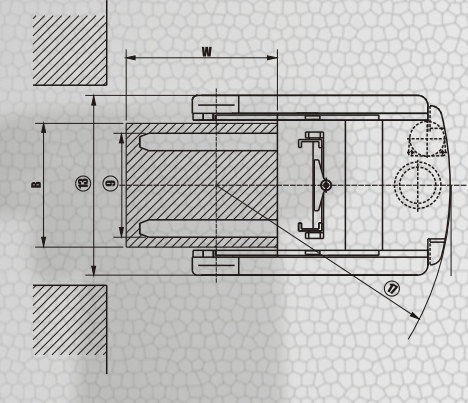

H Series Reach forklift specification

		SFC								
		CQD12H	CQD12H-C1	CQD14H	CQD14H-C1	CQD16H	CQD16H-C1	CQD20H	CQD20H-C1	
General	1 Manufacture									
	2 Model									
	3 Power type	Battery		Battery		Battery		Battery		
	4 Rated capacity	kg		1200		1400		1600		
	5 Load center	mm		600		600		600		
Dimensions	6 Lift height	mm		3000		3000		3000		
	7 Free lift height	mm		340		340		340		
	8 Fork size	L x W x T		mm		920x100x35		920x100x35		
	9 Fork spread(outside)	Min. / Max.		mm		220 / 896		220 / 896		
	10 Mast tilt range	F / R		deg		2 / 4		2 / 4		
	11 Axle centre of fork face			mm		390		330		
	12	Length to face of fork	mm		1802		1802		1882	
			mm		1240		1240		1272	
			mm		2100		2100		2100	
			mm		3565		3565		3565	
	14 Overall dimensions	mm		2075		2075		2075		
		mm		1675		1675		1755		
	17 Turning radius(outside)	mm		1675		1675		1755		
	18 Min. right angle stacking aisle width (Ast)	Pallet: W x B=1200 x 1000		mm		2825		2825		
Pallet: W x B=800 x 1200		mm		2600		2600				
Performance	20 Speed	Travel		Km / h		10.2		10.2		
		Lifting (Full load)		mm/sec		260		210		
	22 Extend distance	mm		602		602		542		
	23 Max. Gradeability (Full load)	%		10		10		10		
	24 Self weight	kg		2850		2850		3000		
Wheels & tires	25 Wheels (diameterxwidth)	Front		mm		285 x 100		285 x 100		
		Drive		mm		343 x 114		343 x 114		
	27 Wheelbase	mm		1420		1420		1500		
	28 Ground clearance	mm		70		70		70		
Drive units & control	30 Battery	Model		D-400B		D-400B		D-500		
		Voltage / Capacity (5 HR)		V / AH		48 / 400		48 / 500		
		Weight (with box)		kg		760		900		
	33 Electric motors	Drive	Model		XQ-5H-1		XQ-5H-1		XQ-5H-1	
			Rated output / r.p.m		kw		5.4 / 1680		5.4 / 1680	
		Load	Model		XQD-7.5-2H		XQD-7.5-2H		XQD-7.5-2H	
			Rated output / r.p.m		kw		7.5 / 2000		7.5 / 2000	
	36 Control	Manufacture		CURTIS		CURTIS		CURTIS		
Type		DC		AC		DC				
37			DC		AC		DC			
38 Operating pressure	For attachments		MPa		14.5		14.5			

LOAD CHART

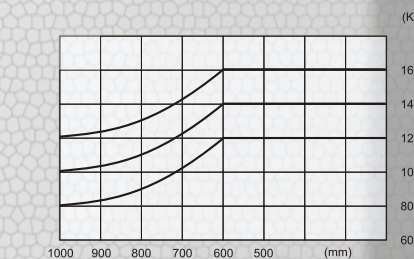

1. Special lifting height available (2.7m, 3.5m, 3.6m, 4m, 4.3m, 4.5m, 4.8m, 5m, 5.5m, 6m, 6.5m, 7m, 7.5m).
 2. Attachment available.
 3. Battery charger available.
 4. The specification in this table are for standard models only. For further information please contact us.
 5. Specification are subject to change without notice.

H series Reach forklift mast specification

Type	Model	Mast fork height	Overall height		Free lift	Tilt range		Capacity			
			Lowered	Extended		Without backrest	FWD	RWD	Load capacity at 600 mm		
					mm				mm	mm	mm
Wide view mast	1.4QM	2700	1925	3265	340	2	4	1200	1400	1600	2000
		3000	2075	3565	340	2	4	1200	1400	1600	2000
		3300	2225	3865	340	2	4	1200	1400	1600	2000
		3500	2325	4065	340	2	4	1200	1400	1600	2000
		3600	2375	4165	340	2	4	1200	1400	1600	2000
		4000	2625	4065	340	2	4	1200	1400	1600	2000
		4300	2790	4865	340	2	4	1200	1400	1600	2000
		4500	2900	5065	340	2	4	1200	1400	1600	2000
		Wide view full free 3-stage mast	1.4QN	4300	2085	4900	1500	2	4	1200	1400
4500	2165			5100	1500	2	4	1200	1400	1600	2000
4800	2265			5400	1600	2	4	1200	1400	1600	2000
5000	2315			5600	1700	2	4	1200	1400	1600	2000
5500	2490			6100	1850	1	3	1100	1300	1500	1900
6000	2665			6600	2000	1	3	1000	1200	1400	1800
6500	2815			7100	2200	0.5	2	900	1100	1300	1600
7000	2975			7600	2380	0.5	2	850	1000	1200	1400
7500	3145			8100	2540	0.5	1	750	900	1100	1200



CE CERTIFICATE



HANGCHA
FORKLIFT TRUCK

H Series
1.2 / 1.4 / 1.6 T
Electric Reach Truck

Standard Feature

- PU drive wheel & support wheel
- High capacity storage battery
- Emergency disconnect switch
- 3 Spools control valve
- Arm rest, head protector
- High elastic seat
- Drive, lift, steering controlled
- LED Instrument and LCD hour meter
- 3 meters 2-stage mast
- Adjustable steering column
- Front head lamp
- CURTIS MOSFET chopper controller
- Separated Excited Motor



ISO14001: 1996

Optional Feature

- Safety pedal
- 4 spools control valve
- 4.3-7.5 meters 3-stage mast
- 2.7-4.5 meters 2-stage mast
- With attachment
- Fast battery-charge system
- High capacity battery
- Front wheel protect cover
- Higher or wider backrest



ISO9001: 2000



ZHEJIANG HANGCHA ENGINEERING MACHINERY CO.,LTD.
(ZHEJIANG HANGCHA IMP. & EXP. CO.,LTD.)

www.hcforlift.com

Add: 398 Shi Qiao Road, Hangzhou 310022, P.R.China
Tel: +86-571-88135110 88126376 88135220 88125527 88130499(Ext. 8116, 8206, 8200)
Fax: +86-571-88132890 88126379
E-mail: sales@hcforlift.com

ZHEJIANG HANGCHA IMP. & EXP. CO., LTD
浙江杭叉进出口有限公司

HCIE is authorised to deal with the whole import & export business of **ZHEJIANG HANGCHA ENGINEERING MACHINERY CO.,LTD.**



浙江杭叉工程机械股份有限公司
ZHEJIANG HANGCHA ENGINEERING MACHINERY CO.,LTD.