



**1t-3.5t R Series Internal Combustion
Counterbalanced Forklift Truck**

OPERATION AND MAINTENANCE MANUAL



Original Instruction

HANGCHA GROUP CO., LTD.

Jun. 2011 5th EDITION

FOREWORD

This operation manual is the explanations that how to use 1t-3.5t R series forklift truck correctly. It will instruct you how to operate safety and precautionary maintenance. To ensure safety and exert the truck's potential, all the personnel that in charge of operation, maintenance and management must read this manual thoroughly before starting work with the forklift.

Compared with 1t-3.5t N series internal combustion forklift truck, 1t-3.5 t R series forklift truck has the following strengths: enhancing the power, improving the outline, using buffer steering axle, in addition, besides the TCM and NISSAN main transmission are configured in our trucks, we also configure Okamura main transmission in our trucks. And there is different between masts of import and export trucks, N series masts are used in the import trucks, R series masts are used in export trucks.

This manual also applies to container forklift truck and forklift truck assembled attachments.

Our product design will update and perform better, so the content in this manual may be not the same as the forklift you owned.

If you have any questions please keep touches with HANGCHA GROUP CO., LTD.

sales department or let the agents know.

Content

Foreword

1. General Rules.....	1
2. Name of main parts or component.....	3
Instruments.....	3
Switches.....	5
Controls.....	6
Others.....	10
3. Safety instructions.....	14
4. Maintenance.....	20
8 hour (daily or every shift) check.....	20
Weekly maintenance (40 hours).....	23
Maintain monthly (166 hours).....	27
Maintain semiannually (1000 hours).....	29
Maintain annually (2000 hours).....	31
Other.....	32
5. Structure and stability of truck.....	35
6. Operation.....	37
Star-up.....	37
Traveling.....	38
Pick up.....	39
Stacking load.....	39
Remove load.....	40
7. Deposit.....	41
8. Maintenance.....	43
Preventive maintenance schedule.....	43
Maintenance of chassis and body.....	45
Table for bolt's tight moment.....	46
Periodic replacement of key safe parts.....	47
Table for the oil used in the truck.....	48
Lubrication system drawing.....	50
Environment protection.....	50
Scutcheons.....	51
9. Truck's convey, lifting, towing.....	57
10. Type signification.....	58
11. Performance parameters of R series IC forklift.....	61
12. Operation, disassembly and installation of cab.....	79
13. Operation and notice about LPG forklift.....	81
14. Operational method of lead acid battery.....	92
15. Use, installation and safety rules of attachment.....	94
16. Related safety instruction and standard.....	96
17. Maintain record.....	100

1. General Rules

To make the truck and you safety, operator should obey these rules below:

1. Only trained and authorized operator shall be permitted to operate the truck.
2. Before start truck you should check all control and alarm device, if there are any damaged or objection, you could not operate it until repaired it.
3. When carry the load, the weight should not much overload. The fork shall insert in the load entirely and well proportioned. It is not permitted use only one fork to load.
4. You should operate the truck smoothly when start, turning, travel, brake and parking. On a slick or wet road, you should decrease speed when turning.
5. Load travel should lower the goods down and tilt the mast backwards.
6. Be carefully when traveled on a grade. If the slope angle is bigger than 10%, travel forward up slope and backward down slope. Never turn sideways and stack load on an incline.
7. Notice the foot passenger, barrier, pothole and the clearance upside.
8. It is prohibit picking up a man or standing on the fork.
9. No permitted to stand or walk under the fork.
10. No permitted to operate the truck or attachment on other position except the operator's seats.
11. Do not carry the load unpackaged. Be carefully to carry these goods with large size.
12. Notice the load not drop from the load bracket for those trucks that overall maximum lift height is higher than 3 meters. If necessary, make some protective measure.
13. Travel with load as low as possible and tilt back the mast.
14. Before driving over a dock-board or bridge-plate, be sure that it is properly secured and strong enough to sustain the weight.
15. Make sure that there is no naked flame near the area, never smoke. The driver should not remain seated when adding fuel.
16. The truck with attachments should be treated as a loaded truck.
17. When leave the truck, you should let the fork down, make the shift lever neutral shut down the engine and cut the power. Parking on a grade, make sure to tighten the brake lever. If necessary, use a block when parking on a grade for a long time.
18. If the truck suddenly get out of order, or for leakage of electrolyte, hydraulic oil or brake oil, when lifting goods or grade climbing, it needs to rush to repair and let the truck be in safe state, then connect with maintainer or sales representative.
19. In the process of install and assemble, it will be noise and libration. Please choose the right tool and assembly method. Depress the noise and libration as soon as possible to reduce the noise pollute to circumstance.
20. The work road surface for forklift should be stability and unknit, cement, blacktop or beton. If there are snows, ice, water or other eyewinker, bar. Eliminate all, and then work. Otherwise the truck will be out of control and lead the safety accident.
21. Move the truck to the place which respects traffic when it anchors. If the reason is brake or turn system, move it by a suitable truck (Reference the part of truck move); Other reasons, use a suitable truck to traipse, tie the cord outside of truck. Please abide by the traffic regulations when traipse the truck on calzada.
22. After take-down the hood, water tank cover board, overhead, backrest of mast, unallowed to operate the truck or load cargo.
23. There are enough light at truck work ground. At night, open the head lamp to

collocate enough lamp-house.

24. Only in the event that the truck manufacturer is no longer in business and there is no successor in the interest to the business, the user may arrange for a modification or alteration to a powered industrial truck provided, however, that the user shall:
- a) Arrange for the modification or alteration to be designed, tested and implemented by an engineer(s) expert in industrial trucks and their safety;
 - b) Maintain a permanent record of the design, test(s) and implementation of the modification or alteration;
 - c) Approve and make appropriate changes to the capacity plate(s), decals, tags and instruction handbook;
 - d) Affix a permanent and readily visible label to the truck stating the manner in which the truck has been modified or altered together with the date of the modification or alteration, and the name and address of the organisation that accomplished the tasks.

2. Name of main parts or component

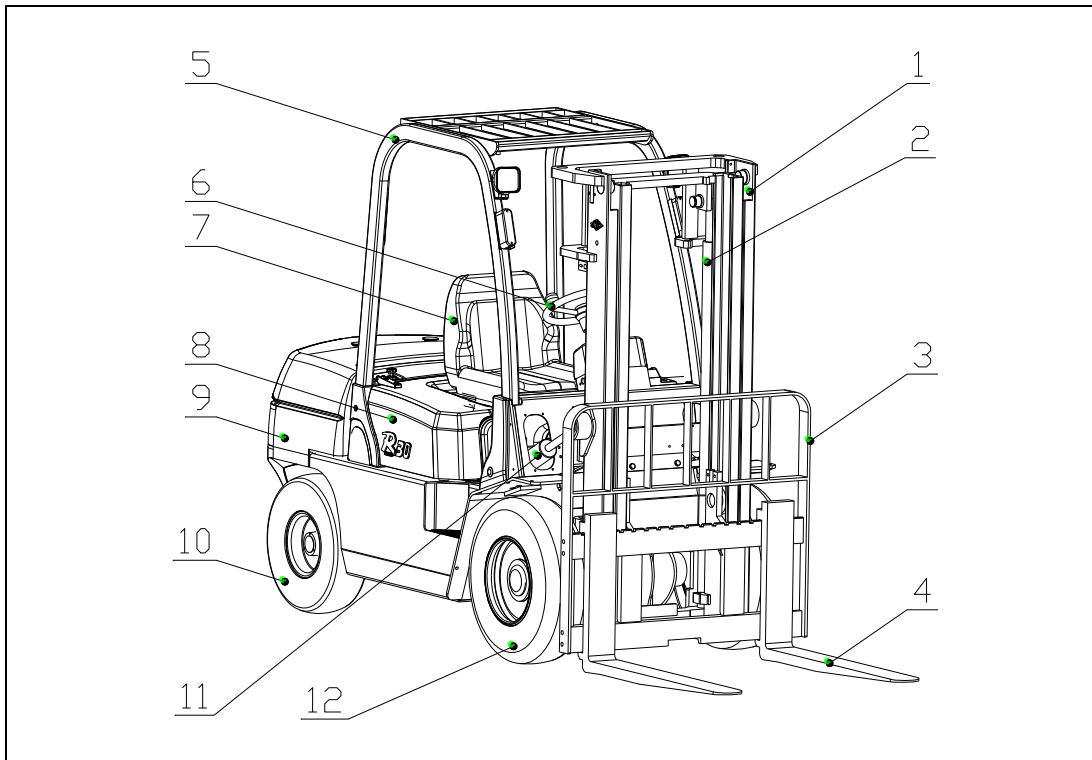

- | | | | |
|--------------------------|---------------------|----------------------|-----------------|
| 1. Mast | 2. Lifting cylinder | 3. Backrest | 4. Fork |
| 5. Overhead guard | 6. Steering wheel | 7. Seat | 8. Cover hood |
| 9. Counterbalance weight | 10. Rear wheel | 11. Tilting cylinder | 12. Front wheel |

Instruments

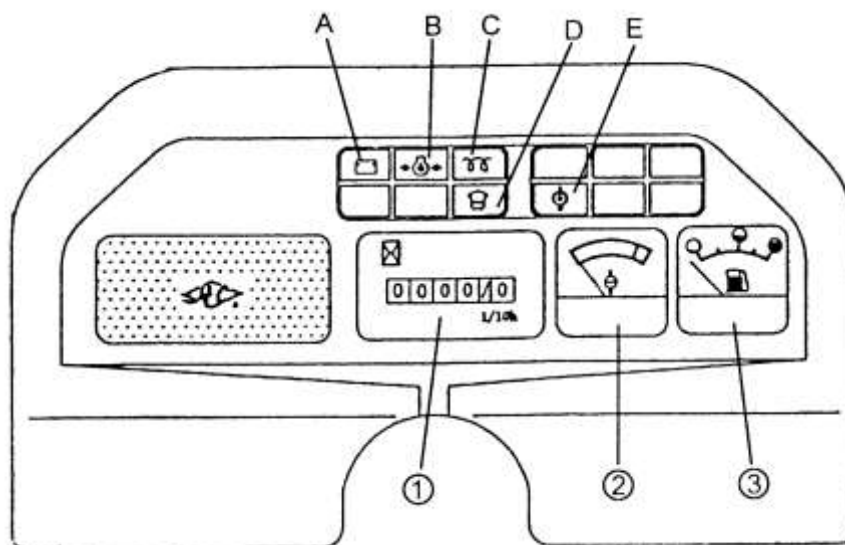

Hour meter [1]

This meter measures working time of engine. Use meter to schedule lubrication and maintenance periods.

Water temperature gauge [2]

This gauge indicates the oil temperature in the torque converter transmission box. In normal status, the pointer is in green zone. (60°C ~115°C)

Caution

If the pointer points red zone, please stop the truck at once. Decrease the engine speed to make the engine cool. Check the cooling fluid if enough and the fan belt's elasticity if fit.

Fuel gauge [3]

The gauge indicates the fuel level in the tank when the key is at I (ON) position.

Charge (A)

This lamp indicates the battery condition of charge. The lamp comes on when the ignition switch is set at "ON", but it goes out as the engine starts and accelerator pedal is pressed.

Caution

If the light continues to stay lit or lights up during operation, the charging rate is low and should be checked immediately.

Oil pressure alert lamp (B)

This lamp indicates the pressure condition of engine lube oil. Although it lights up when the engine switch is set at "ON", once the engine starts up and the accelerator pedal is pressed, this lamp goes out.

Caution

If this light continues to stay lit or lights up during operation, the pressure is lower than 0.05Mpa and should be checked immediately.

Glow indicator (C) [Diesel truck]

Turn the key to "ON" position and the indicator lights up for a moment. After the indicator goes out, turn the key to  "Start" position.

Sedimentor indicator (D) [Use in W9、W13、W15A diesel truck]

In normal state, once the starter is set to  "ON" position, this lamp lights up. After the engine is started up, it goes out.

This lamp lights up when water in sedimentor reaches to a certain level, while the engine is running.

If this lamp continues to stay lit or lights up during the engine running, stopping the engine and discharge water immediately.

Caution

Fuel injection pump will be damaged if continue working when the light is up.

Engine coolant temperature [E]

In normal state, once the starter is set to  "ON" position, this lamp lights up. After the engine is started up, it goes out.

During work time if the oil temperature exceed the normal rang (60°C~120°C) the indicator light on.

Caution

If the pointer enters the red range, stop the operation instantly and slow down engine speed to cool the coolant and wait until the pointer goes into the green range, and have a check then.

Switches

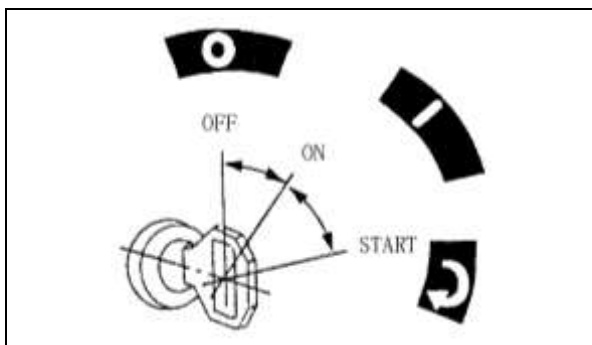
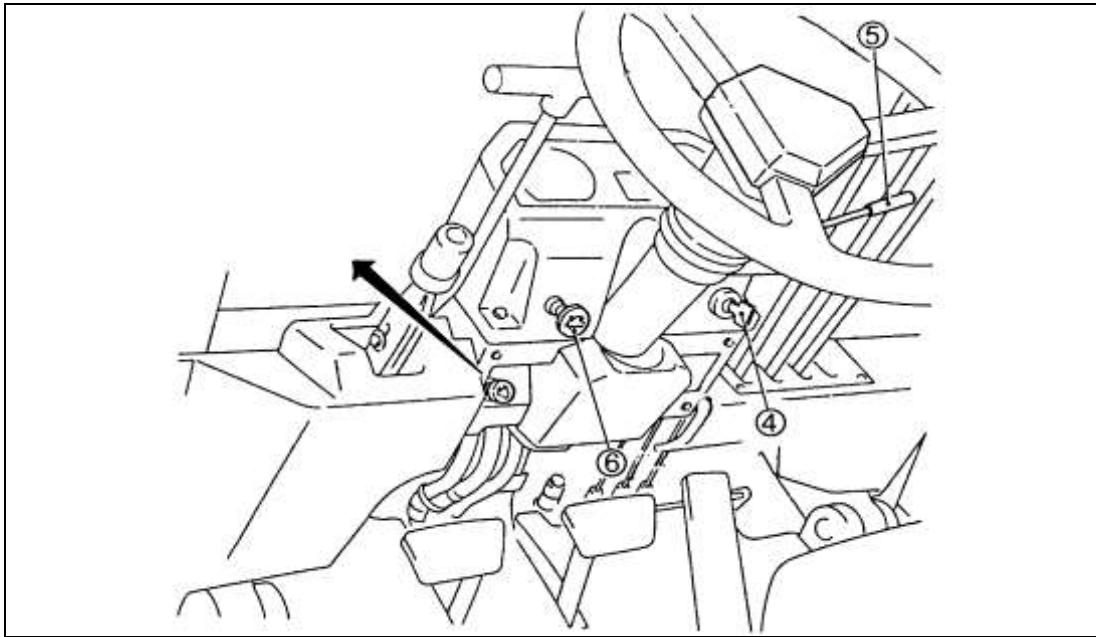

Key [4] OFF (O)

This is the position at which the key inserted or drawn out.

Gasoline engine and diesel engine stop at this position.

ON (|)

The electric circuit is closed with the starter switch at “|”(ON). After the engine is started, the key is at this position.

START (↷)

As the key is placed in the “START” position, the starter motor is engaged. When removing hand off key, it is automatically returned to the “ON” position by spring force.

Diesel engine

Turn the key to “ON” position and the indicator lights up for a moment. After the indicator goes out, turn the key to “Start” position.

Caution

1. Do not keep the starter switch in the “|”(ON) position while engine is shut down. This result in a discharge battery.
2. With the engine running, do not turn the starter switch into the (START) position, since there is a danger of the starter motor being damaged.
3. Do not keep the starter engaged for more than 5 seconds at a time. Wait about 120 seconds before trying again.

Turn signal lever [5]

Use this lever which is at the right side of turning rod to indicate the turning direction of the truck. **R**-turn right, **N**-neutral, **L**-turn left.

The turn signal level does not automatically return to the neutral position unlike general passenger cars. Reset it by hand.

Light switch [6]

This light switch can be pulled out at two steps.

Light Stage	Power	Near light	Far light	Clear-ance
0	x			
1 st	x	x		x
2 nd	x		x	x

(x) means connected

Horn button [7]

Press the rubber cover at the center of steering wheel to sound horn.

Controls

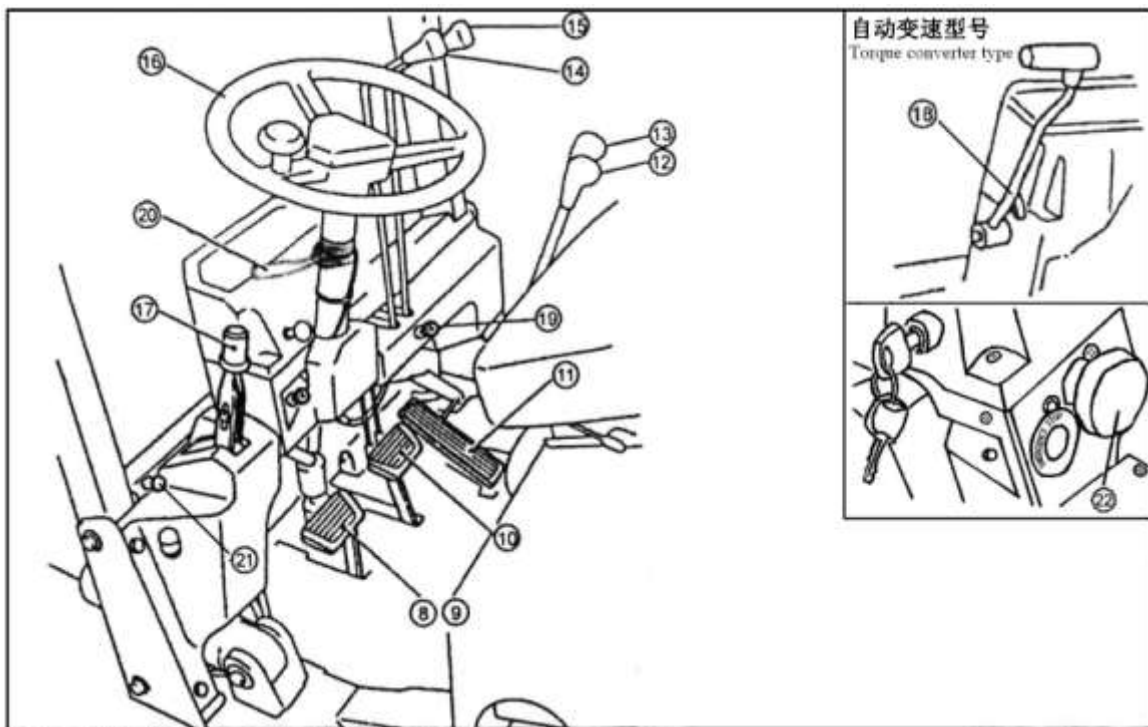

- 8. Clutch pedal (frictional clutch type)
- 9. Inching pedal (torque converter type)
- 10. Brake pedal
- 11. Accelerator pedal
- 12. Forward reverse and Speed select lever (frictional clutch type)
- 13. Shift lever
- 14. Tilt lever
- 15. Lift lever
- 16. Steering hand wheel
- 17. Parking brake lever
- 18. Forward reverse lever (Torque converter type Non-electric-switch)
- 19. Choke
- 20. Forward reverse lever (Torque converter type Switch)
- 21. Guy head
- 22. Emergency Stop Label

Pedal

Clutch pedal [8] (frictional clutch type)

Press the clutch pedal fully, the operator can uncouple the engine and transmission.

When the clutch pedal released, it allows power to flow through the clutch from the engine to transmission.

Caution:

Do not run the lift truck with the clutch in a half-clutch condition as much as possible.

Inching pedal [9] (Torque converter type)

As the inching pedal is pressed, the oil pressure in the hydraulic clutch drops accordingly (the needle of the oil pressure gauge swings to the left) allowing the operator to perform inching operation. Use this pedal to inch the truck while operating the hoist system at a high speed.

When pressed to the full, this inching pedal serves as a brake pedal also.

Caution:

Do not use the inching pedal too much. Long time use or use as rest would cause high temperature of transmission oil, or result in slipping of clutch.

Accelerator pedal [11]

Press down the accelerator pedal, engine rotating speed increase, traveling speed of truck increased. On the contrary, when loosen the pedal, engine rotating speed and truck traveling speed will decrease.

Forward-reverse [12] Speed-select lever [13]

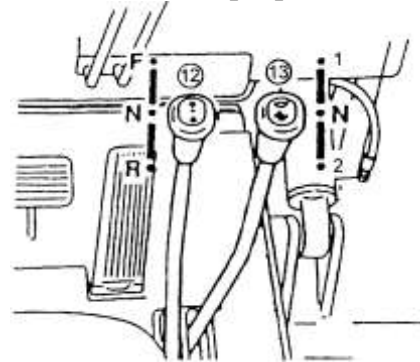

Machinery transmission

[12] F-front N-neutral R-backward

[13] 1-low N-neutral 2-high

Machinery gear box have four shifts, tow are frontward and tow are backward.

Before gear-shifting, be sure to press the clutch pedal to the full. Always brake to a full stop before reversing the direction of travel. Shifting the level in reverse the back-up lights turn on.

Lift lever [14]

Control the forks' up or down.

Pulling: up, Pushing-down.

Lifting speed can be controlled by tilt backwards angle of lever and accelerator pedal, the lowering speed can be controlled by tilt forwards angle of the lever.

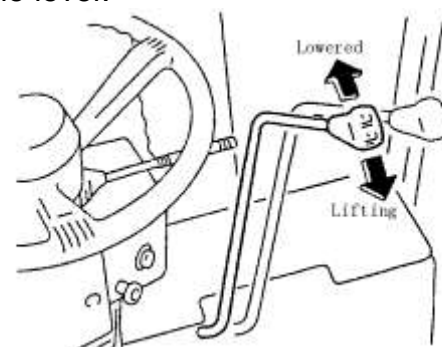

Tilt level [15]

The mast can be tilted by operation of this tilt lever: pulling on this lever backwards will tilt the mast backwards, and pushing it forwards will tilt the mast forwards.

The tilt speed can be controlled by tilt angle of the lever and accelerator pedal effort.

Caution:

The tilt lock mechanism built in the hydraulic control valve does not allow the mast to tilt forwards while the engine is being shut down even if the tilt level is pushed forwards.

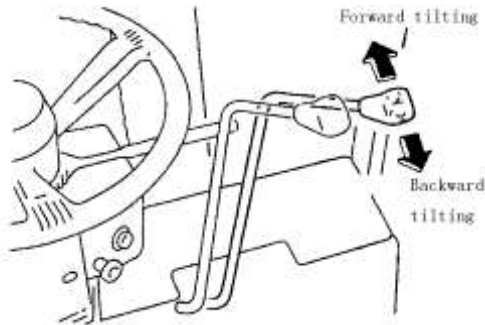

Steering wheel [16]

The steering hand-wheel is operated in the conventional manner, that is, when the wheel is turn right, the truck will turn to the right; when the wheel is turned left, the truck will turn the left. The steer wheels are located at the rear of the truck. These cause the rear of truck to swing out when a turn is made.

Warning

This truck is provided with the power steering, so heavy hand-wheel operation is caused when the engine comes to a stall. To put the power steering in operation again, restart the engine without delay.

Parking brake lever [17]

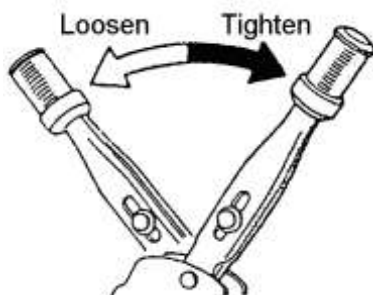

Pull the parking brake lever backward to park, push it forward to

release, must pull the parking brake lever backward before driver leaving truck.

**Forward reverse lever [18]
[Non-electric-switch]**

F-forward **N**-neutral **R**-backward

Torque converter type truck have a forward shift and a backward shift. When shift must stop the truck first.

Caution:

Do not fail to place the forward-reverse lever in the neutral position before starting the engine.

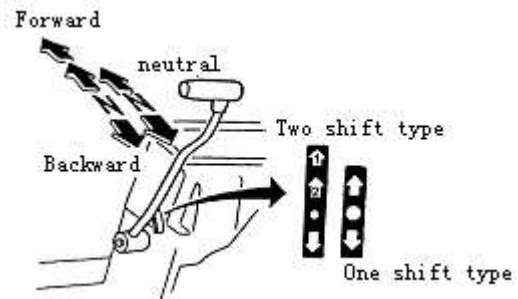

Choke line [19]

To pull out the choke line, the engine will stop. Some of the model forklift has no choke line. When turn off the key switch, the engine will stop.

**Forward-reverse lever [20]
[Electrical Switch]**

The forward reverse lever of truck installed with electronic reserving is set on the left of turning rod.

Forward—Forward **N**—neutral After allocation—backward

Caution:

Do not forget to place the forward-reverse lever in the neutral position before starting the engine

Guy head [21]

Hood and snap close

To avoid opening the hood at discretion, a snap close is set here. Open the snap close first then the hood can be open.

Guy head

To avoid opening the hood at discretion, the hood only can be opened by specified tools. The guy head is the specified tool.

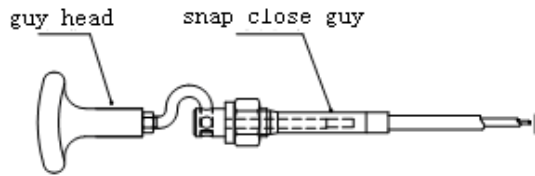

Emergency stop switch [22]

Switch is located below the steering wheel on the right.

Pressing the switch will cut off the power of electric element from battery.

if you want to restart the truck, you have to pull up the switch.

Others

Load bracket

Load bracket can ensure stabilization when loading the goods. It's forbidden to use the forklift truck without the load bracket.

Seat and seat adjusting lever

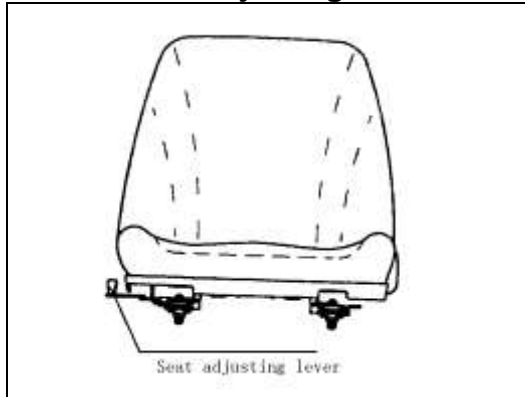

Adjust operator's seat to position, which is comfortable for you and provides easy access to all hand and foot controls. The seat is unlocked by moving the adjusting lever to the right. Before proceeding with work, adjust operator's seat and make sure that it is securely locked.

Warning

- a. Before adjusting the lever, you'd better turn off the key switch.
- b. Must stop the truck to adjust the seat.

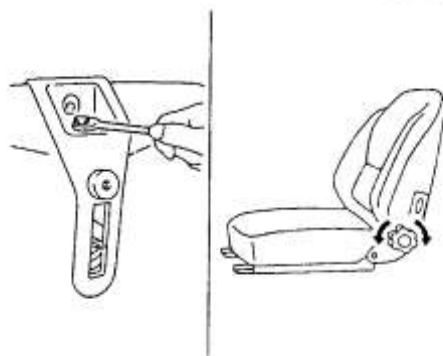

Seat weight support adjusting

Use spanner to adjust the bolt which is at the back of seat, or adjust the knob for supporting the weight on seat at the lift side of seat, adjust the

hanging's weight basing on person's weight.

It's better to sit on the seat when adjusting.

Seat switch

While you are on the vehicle and wearing the Safety belt, at the same time, your back and waist should close to the seat as much as possible.

Check whether the bolts which fixed seat belt were loose frequently. It is forbidden to use the Safety belt when the belt was tie a knot. Do not let the belt press on the hard or fragile objects. And also do not make friction with the sharp edge to avoid damaging the belt. Do not let the seat back tilted too much; otherwise the safety belt will not be able to correctly elongation.

The components which are on the safety belt can not be removed randomly. If the safety belt used frequently, you should always do exterior inspection, when found something abnormal, please immediately replace new belt. The belt can be used for 3 to 5 years, when found something abnormal, it should be scrapped early.

Overhead guard

The overhead guard used is strong enough to meet safety standard, and protects the operator from falling materials. It's forbidden to use forklift without overhead guard.

Hood

The hood can be swung up fully to provide easy maintenance service. You can lift up the hood with little effort with an aid of hood damper. To lock the hood, push down on the front of hood until it covers.

Caution:

Before open the hood, the handle of the snap close should be pulled out first.

Use caution not to catch your fingers in the hood when closing it

Caution

While maintaining under the cover hood, the engine must be flameout to avoid hands or other parts of the body being clamped by running assembly. The engine can be no-flameout only when human body does not touch parts under cover hood, and to examine where the fault is by hearing.

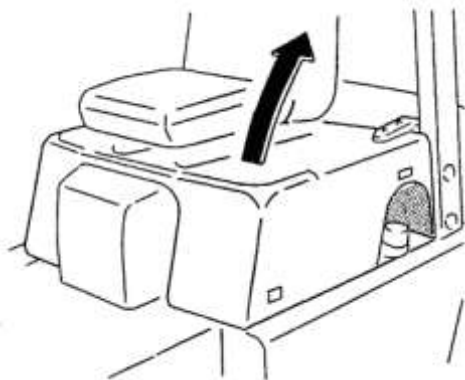
Radiator cover hood

Must use special tools (socket spanner) to open radiator cover hood.

You can open the radiator cover hood even close the engine hood, so to inspect the coolant fluid.

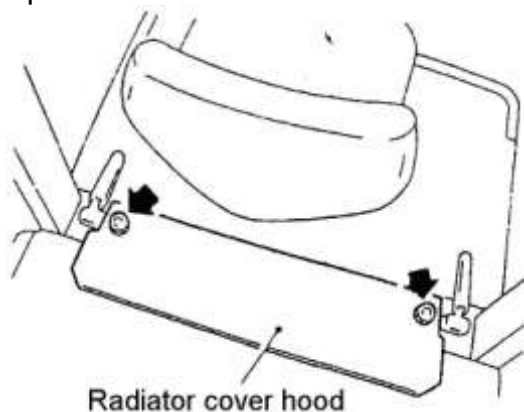
Caution:

Retighten the bolt on the cover hood.

Radiator cap and coolant reservoir

The reservoir is located inside the hood.

The radiator is located under the cover plate at the rear of the hood.

Warning!

Do not open the radiator cap abruptly while water's temperature is higher than 70°C. Turn the cap a little to the left to relieve the pressure in the pressure in the radiator, and then remove the cap.

Do not wear glove when removing radiator cap.

The antifreeze fluid is dangerous for your health, if touched to skin, please wash clean by water. Do not allow children access to antifreeze.

Fork stopper

It's used to adjust fork spacing and to lock the forks in position. Pull up fork stoppers, turn 90°, according to loads to handle the forks spacing.

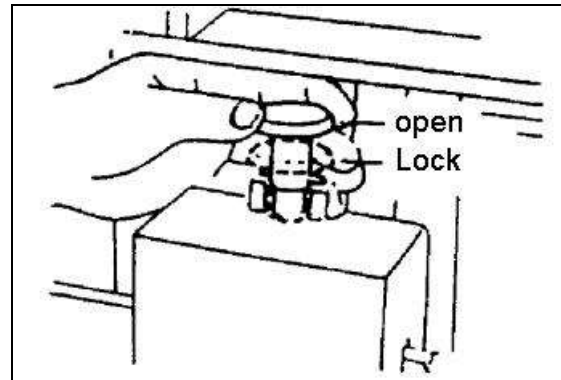

Warning!

The forks should be set symmetrically to machine centerline and fork stoppers should always be set.

The lower beams of fork have a hatch to load or unload forks.

The fork is forbidden to fix on the location where the hatch locates. Check the bolt at the middle of the fork bracket which is used to prevent load fork at the hatch.

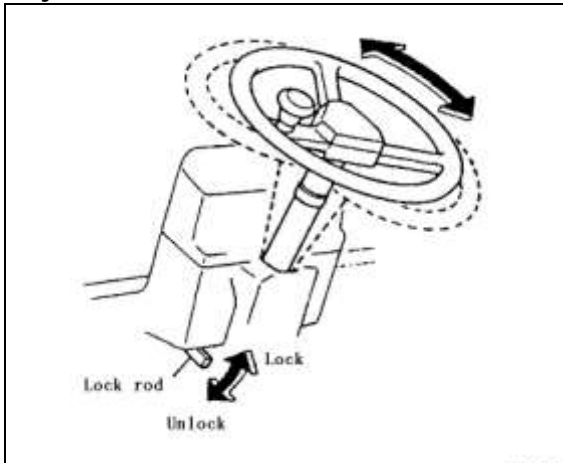
Steering column tilting angle adjustment



The tilting angle of the steering wheel is adjustable to suit individual operators. The steering column is unlocked by pushing down the lever at the left side of turning rod, then adjust the angle suit to the driver, and pull up the lever to lock.

Caution:

- After stop the truck and pull on the parking brake lever then to adjust the tilting angle of steering column.
- After adjust the angle and pull the steering wheel to make sure tighten the lock rod.

Safety step and safety grip

The safety steps are provided on both sides of the truck body. The safety grip is provided on the front left pillar of the overhead guard. Use the safety step and safety grip facing the truck when get on and get off the truck.

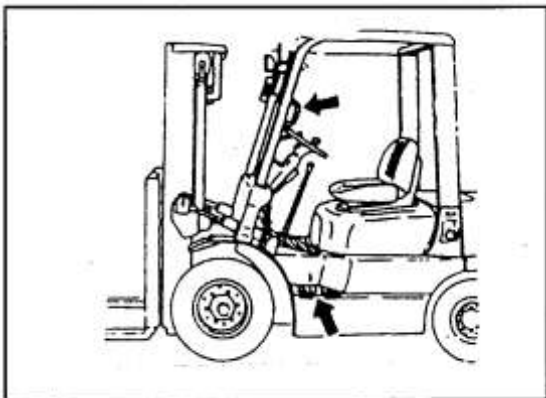

Brake fluid reservoir

The brake fluid reservoir is provided at the left of the cabinet.

Hydraulic fluid reservoir cap

The hydraulic fluid reservoir cap is located at the right side in the hood. Fill hydraulic fluid through this filler port. The cap is provided with the dipstick. After fill in clean hydraulic fluid, lock the cap.

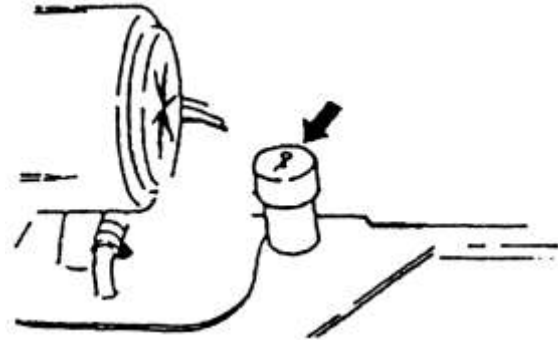

Fuel reservoir cap

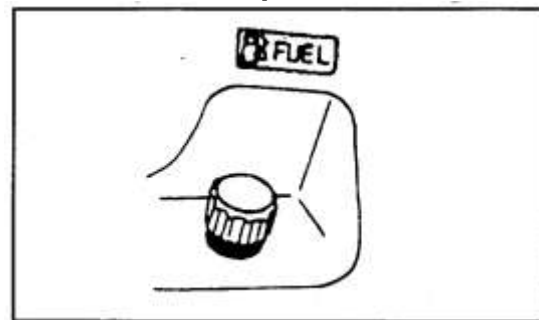

The fuel reservoir cap is located at the rear left side of the truck body. The fuel reservoir cap has the breather inside it to allow air to enter the reservoir. Check to see that the breather is in good condition every time addition of fuel is made.

Warning!

--- Fuel handling---

1. Stop the truck, shut down the engine and apply the parking brake securely. Make sure that there is no naked flame near the area. Never smoke. The driver should not remain seated when adding fuel.
2. After addition of fuel is finished, securely close the reservoir cap. A loose cap could cause fuel leak or fire hazard in the worst case.
3. Before attempting to start the engine, make certain that the fuel reservoir cap is securely tightened and that no fuel is split on or around the truck.
4. For the purpose of fuel level inspection, never use naked flame such as a match or lighter.

Rearview mirror

There are two rearview mirrors on the safeguard for operator to see rear accident.

3. Safety instructions

1. Only trained and authorized operator shall be permitted to operate the truck.

2. Inspect the truck at periodic intervals for oil or water leak, deformation, lousiness, etc. If neglected, the life of the truck will be shortened and in the worst case a fatal accident would occur.

Make sure to replace the “key safe parts” at periodical inspection.

Wipe off oil, grease or water from the floor board and foot and hand controls, if any.

Shut down the engine before inspecting the engine and its allied components. Especially use caution to the engine fan.

When inspecting the radiator or muffler, exercise caution not to get burnt.

3. Any time you find that the trucks are not functioning properly, operation of the truck should be halted and the condition reported to the supervisor.

When doing maintenance in the high place (such as mast, front and rear lights) should be care of slide and clamped.

If any warning lamp comes on, move to a safe place and check or repair the trouble.

When doing maintenance, take care of edges and corners to lacerate hands, head and other parts of body.

The sign of defect should be put on the defecting forklift truck.

4. Don't use an open flame to check level, or for leakage, of fuel, electrolyte or cooling water.

Never smoke while inspecting the battery, handling fuel or working on the fuel system. There is a danger of explosion.

At working place fire extinguisher should be prepared.

Never fill the fuel tank with the engine running.

5. Warm up the temperature of water to 70°C before operation; and cool down the temperature of water to lower than 70°C after work.

If the temperature of the water tank is higher than 70°C , never open the tank cap.

6. When using your truck in an enclosed space, make sure there is enough ventilation. If needed, use a ventilation fan. Don't work in a closed working space because of the tail gas of truck is dangerous to health.

It's forbidden to use truck under a circumstance of flammability and easy to blast.

7. Never mount or dismount the moving truck. Use the safety step(s) and safety grip facing the truck when mounting or dismounting the truck.

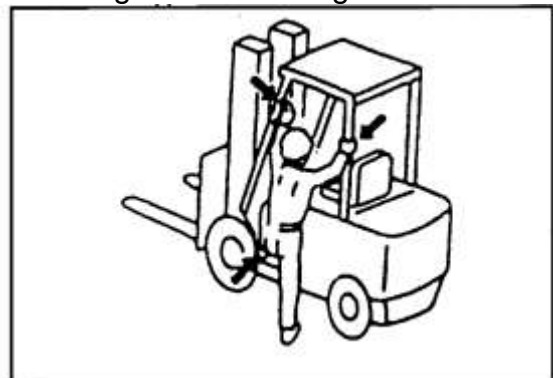

8. Never attempt to work the controls unless properly seated.

Before starting, adjusting the seat so you can get easy access to all hands and foot controls.

9. Before starting, make sure no one is under, on and close to the truck.

The forward-reverse lever is in neutral.

10. Park the truck on a level surface and apply the parking brake securely. If parking on a grade is unavoidable, be

sure to block the wheel.

Put the forks on the ground or floor and tilt a little forwards. Shut down the engine and remove the key.

11. Operate the controls smoothly-don't jerk the steering wheel. Avoid sudden stops, starts or turns.

12. Control speed and observe traffic signs.



When traveling on public roads or streets, obey all local traffic regulations

13. Pay attention to the route of the truck, be sure to make a wide sight.

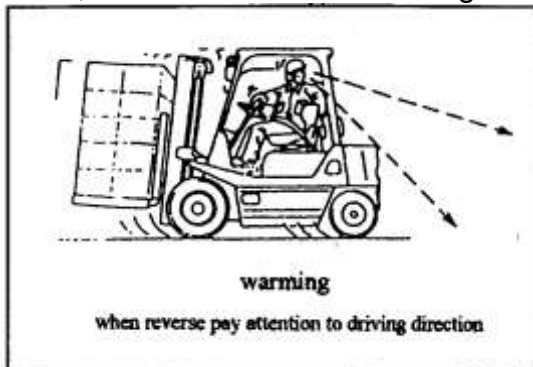

14. Never allow other person(s) to ride on the forklift. Does not allow other people sitting on the forks, pallets or on the truck.



15. Before driving over a dock-board or bridge-plate, be sure that it is properly secured and strong enough to sustain the weight. Check the ground or floor condition of working area in advance.



16. Keep your mind on your work.

17. Keep your head, hands, arms, feet and legs within the cab. Never let them out of cab for any reason.

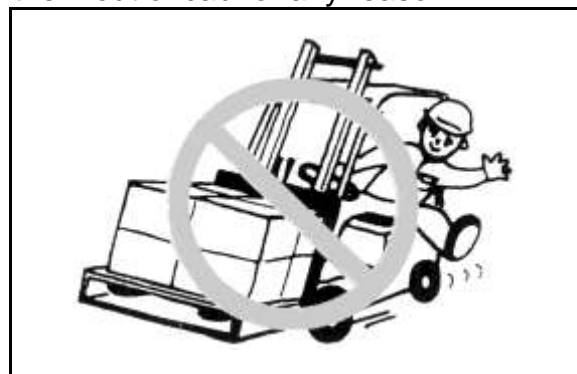

18. When handling bulky loads, which restrict your vision, operate the truck in reverse or have a guide.

19. Slow down and sound horn at cross aisles and other locations where vision is restricted. The speed should be kept slower than 1/3 of max speed.

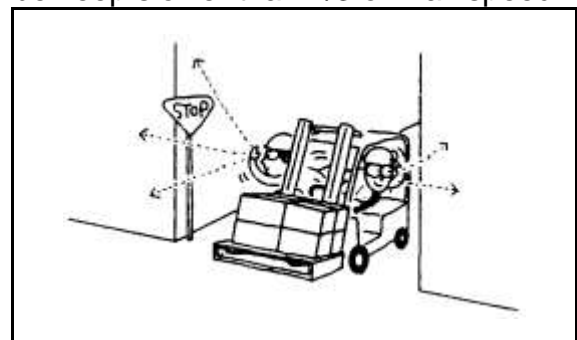

20. Keep fluid cans, row cotton, paper or chemicals away from the truck during operation since there is a danger of their firing or exploding due to exhaust gas from the muffler.

21. Use head lights and required work light and clearance lights at night. And travel at a low speed.

22. The work surface should be solidly and flatness such as cement road surface, bituminous macadam and beton road surface.

The climatic conditions that the trucks designed for are: temperature is -20°C — 50°C ; wind speed is lower than 5m/s; air relative humidity is less than 90%(20°C).

Inspect the surface over which you will run. Look for holes, drop-offs, obstacles, and look for rough spots. Look for anything that might cause you to lose control, bog down or upset.

Clear away trash and debris. Pick up anything that might puncture a tire or let the load lose balance.

Slow down for wet and slippery roads. Stay away from the edge of the road. If unavoidable, use extreme caution.

Rugged surface would cause vibration of truck and noise. The high air pressure of tyres will cause vibration and noise, too.

Do not operate the truck when the weather is execrable, such as windy, thunder storm, snow and etc.

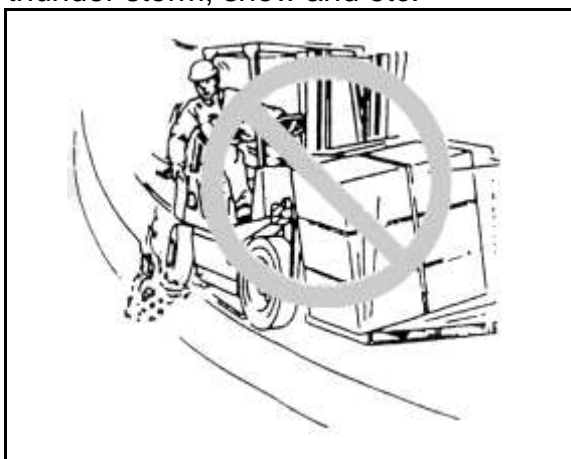

23. When operating loaded truck, have the rear end of your machine pointed downhill. When operating unloaded truck, have the rear end of your machine pointed upgrade.

Never turn sideways on an incline. There is danger of the truck turning over.

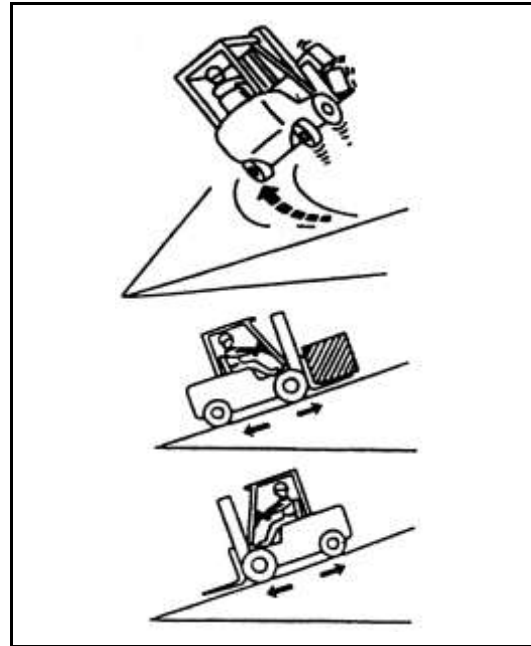

24. When running down on a grade, use engine idle speed. At the same time use the brake pedal intermittently.

25. It is dangerous to travel with forks higher than appropriate position regardless of whether loaded or not. Keep the good traveling posture. (When traveling, the forks should be 15 to 30 cm above the ground or floor.)

Do not operate the side shift mechanism, if equipped, when the forks are raised and loaded, since this will cause the truck to be unbalanced.

A truck with attachments should be considered as with loads.



26. Travel with load as low as possible and tilted back.

27. Avoid braking too sharply or descending on a grade at a high speed. There is danger of loads falling down or the truck turning over.

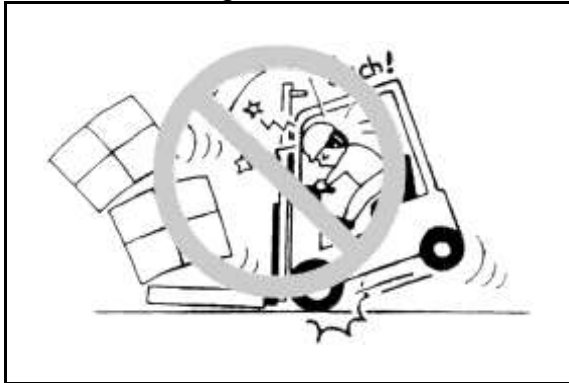

28. Always brake to full stop before reversing direction of travel.

29. Taking account of the shape and material of loads to be handled, use a proper attachment and tools.

Avoid hoisting the load, with wire rope hung on the forks or attachment, since the wire rope may slide off. If needed, a qualified personnel for slinging operation should perform, making use of a hook or crane arm attachment.



Take care not to protrude the forks out of the load. The protruded fork tips may damage or turn over the adjacent load.

30. Know the rated capacity of your lift truck and its attachment, if any, and never exceed it.

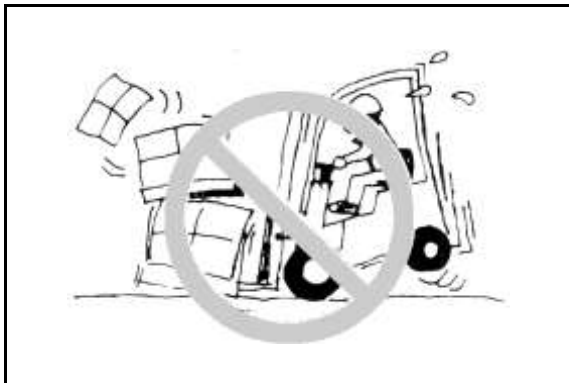

Do not use a man as an additional counterweight. It's quite dangerous.

31. HANGCHA offers a variety of attachments, such as forks, bucket, rotating roll clamp, load grab or hinged forks. Don't use such attachments and special equipment for applications other than specified.

32. Safeguard is used to prevent us from hitting of the higher goods. Load bracket is used to ensure loading stable. The forklift truck without two items is forbidden to be used.

33. Never permit anyone to stand or walk under upraised forks or other attachments if machine is so equipped.

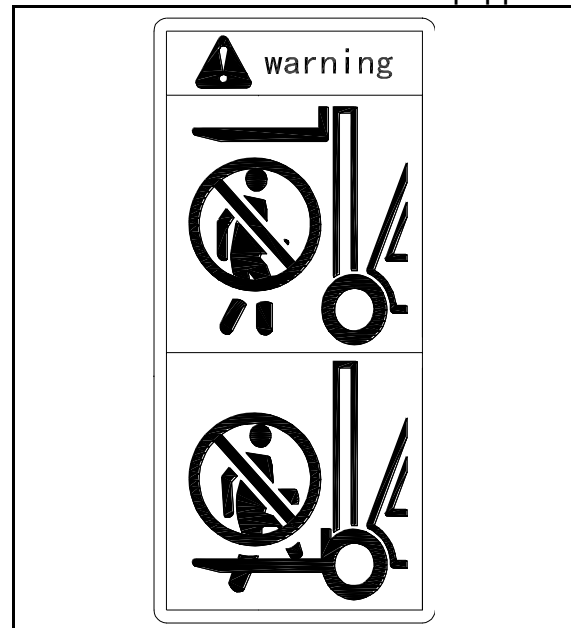

Never permit anyone to stand on the forks.

34. Don't put your head or body into the interspace of mast and safeguard, what may cause life risk

Don't put your hand into the interspace of inner mast and outer mast

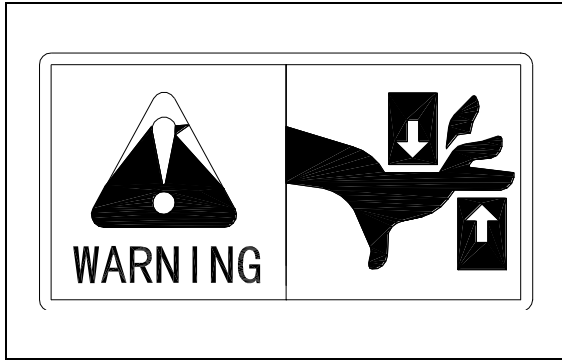

35. When load is to be retrieved from a pile, enter the area squarely. Engage forks into the pallet carefully.

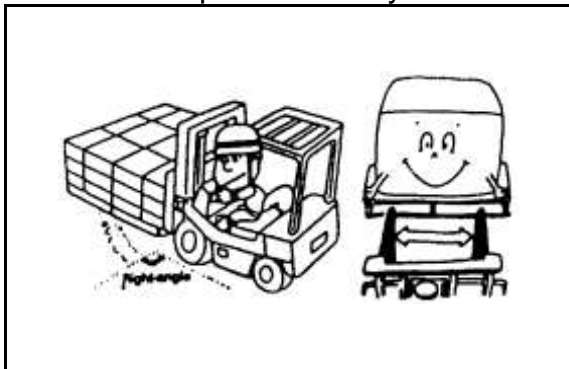

36. the goods is liable to drop turning or passing rough road when it departs the center. And the forklift may turn over more probably.



37. Don't enter into loads at a high speed. Always make certain that your load is stable before lifting the forks.

Be sure to once stop in front of the load to be lifted, and make certain that there is no obstacle, then engage the load by driving forwards.



38. Make certain that your load is well stacked and evenly positioned across both forks. Don't attempt to lift a load with only one fork.

On the truck with an attachment such as a load grab, make certain that the load is securely and correctly grabbed, and pull the loading control level to the full (increase to relief pressure).

39. Never lift loads with the truck inclined. Avoid loading work on a grade.

40. Don't stack loads on forks in such a way that the top of loads exceeds the load backrest height. If unavoidable, make the load stable securely. When handling bulky loads that restrict your vision, operate the truck in reverse or have a guide.

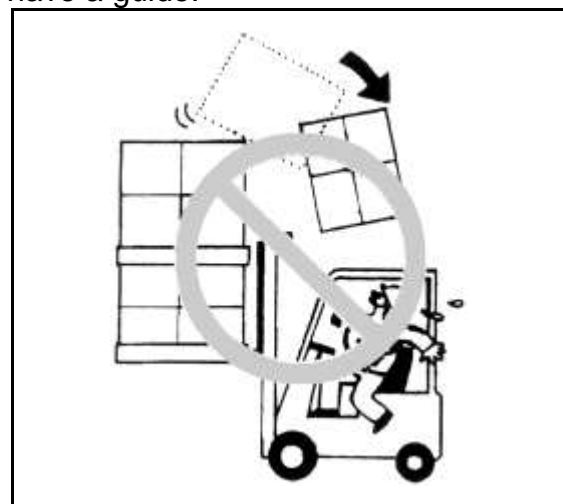

41. Use minimum forward and reverse tilt when stacking and unloading loads. Never tilt forward unless load is over

stack or at low lift height.

When stacking loads on a high place, once make the mast vertical at a height of 15cm to 20 cm above the ground and then lift the load farther. Never attempt to tilt the mast beyond vertical when the load is raised high.

To unloading loads from a high place, insert forks into the pallet and drive backwards, then lower the load. Tilt the mast back after lowering. Never attempt to tilt the mast with the load raised high.

42. Don't tow the truck that its engine is in trouble, or steering system doesn't work correctly or its braking system has been disabled.

Obey the communication rules on the road when towing the truck.

43. Dress the overalls or other protective uniforms, such as safety helmet, safety shoes etc. Don't dress necktie or other accouterments.

44. The workplace should be equipped with fire extinguisher. In order to get the fire extinguisher easily, it's usually installed on the safety frame rear supporting leg. The operator should be familiar with position of the fire extinguisher and its application.

45. Not allowed to carry small goods with fork, should carry small goods with pallet.

46. Markings on the machine describe warning and methods to operate the lift truck. When operating the machine, observe and follow all markings on the machine in addition to this operator's manual.

Replace damaged or missing decals and name plate.

4. Maintenance

More details for maintenance see
《 Preventive maintenance schedule 》 .

8 hour (daily or every shift) check

1). Check leaks: electrolyte, hydraulic oil, brake fluid, coolant, oil in hydraulic transmission gear box.

Check if the engine, connector of hydraulic pipe, radiator and driving system are leakage or not. Do not use an open flame to check level, or for leakage, of fuel, electrolyte or cooling water.

Warning!

Don't attempt to operate the truck if leaked fuel is found through pre-operational check. Correct the leak before starting engine

2) Check appearance

Check the lamps and meters are normal or not.

Check the tires, air pressure and bolts are loose or not.

Check whether tires are damaged or pressure of tires is normal or not.

3) Check fuel mass



The fuel level gauge is provided on the indicator panel. Check that fuel level is sufficient for the day's work. The fuel filler port is provided at the rear left pillar of the overhead guard.

Engine oil level check

Caution

Caution:

When checking the engine oil, should let the forklift truck on the level ground.

When check the engine oil, it is exact when the engine is cool.

Remove the dipstick, clean the rod and reinstall. Pull it out again and check the oil level. The level should be within the mark on the dipstick.

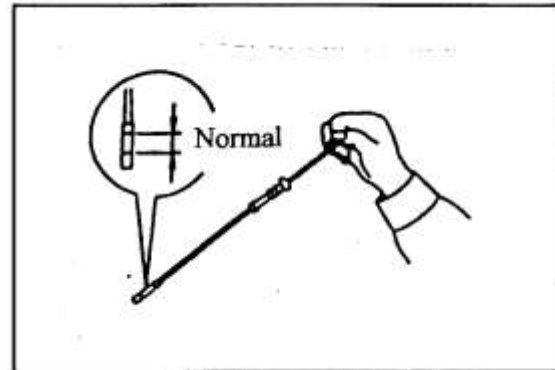

5) Check water level in the radiator

Inspect the small reservoir tank to see the coolant level is between Min and Max position when the engine is cool. If there is no coolant any more in the reservoir tank, please add some coolant to radiator, its freezing point is -35°C , and add sub-radiator to MAX position.

Warning!

When the water temperature of the engine is higher than 70 degree, please do not open the pressure cap of the radiator. Loosen cap slowly to allow steam to escape. After that, tighten cap securely. It is good practice to use thick waste cloth or the like when removing the cap. Avoid putting on gloves, since you may get burnt at your hand if hot water splashes on it.

Caution

Adding clean water to radiator. If you use antifreeze, use the same brand of antifreeze.

Pay attention to water reservoir and cooling system in the hot season..

⚠ warning

- antifreeze is harmful to person, if swallow, disgorge at once and go to hospital.
- do not let children add antifreeze

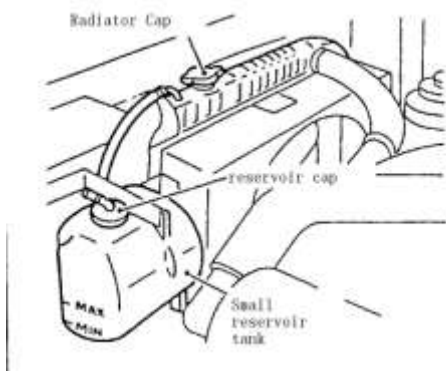

6) Hydraulic oil level

Check the oil level in the hydraulic oil tank.

The oil level should be in the place between two slots,

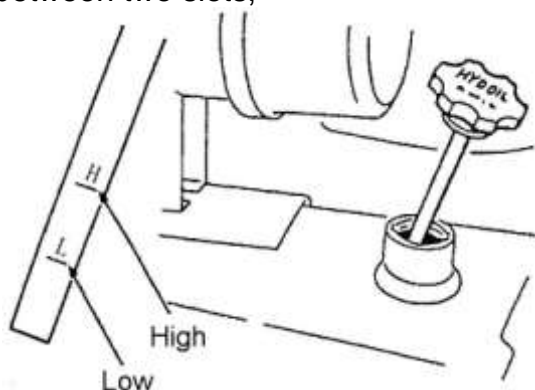

Brake fluid level check

Check the fluid level in the brake fluid reservoir. The level should be between the two seams of the reservoir. When adding fluid, due care should be taken prevent air entering the brake tube.

Caution

When adding fluid, due should be taken to prevent dirt or water from entering the reservoir.

Brake fluid is dangerous to health, you should avoid touching it by skin.

Replacing of brake oil

- 1). Lay forklift truck at designated ground, and lay it on level ground, fall down fork to ground, loosen park brake, put transmission gear neutral position, cut off engine.
- 2). Remove rubber dustproof cap of oil-drain port, insert tube into oil-drain port and wasted oil collection bottle, and loosen oil-drain screw, at the same time, the other person on truck press brake pedal again and again. So the brake oil flows out from oil-drain port, watch the liquid level of brake fluid reservoir, add new oil as the fallen liquid level until the oil from oil-drain port is clean, and then screw down screw of oil-drain port.
- 3). The person on truck press down brake pedal to the end and keep it, at the same time, the person at the oil-drain port loosen oil-drain port screw, tell the person on truck to release brake pedal when the brake oil flows out and screw down oil-drain port screw. Repeat above operation several times till there is no bubble in the brake oil. Watch the liquid level in brake oil reservoir; add new brake oil as the liquid level is falling.

Notice:

The truck of Korea transmission system: The brake oil (in the brake oil can) is MobilDelvac hydraulic oil SAE10W.

Other types: choice HZY3 brake oil (add when leaving the factory) or DOT3 brake oil.

Head lamp check

Make sure that the head lamp is lighting when the key is at "ON" position.

Turn signal check

Make sure that the turn signal operates properly by moving the turn signal lever.

Hand brake check

- ① Drive truck slowly.
- ② loosen hand brake lever, stop the truck, and truck has no deviation.

Back-up lamp and buzzer check

The back-up lamp comes on and buzzer sounds when the shift lever or directional control lever is placed in reverse position.

Turning

- ① Operate the truck running slowly.
- ② Turn the steering wheel to left and right 3 round respectively.

Check that the steering forces are equal in right and left.

Horn

Press the horn button to make certain the horn sounds is normal or not.

Drivers seat adjustment

Make sure the driver's seat is properly located. If not properly, shift the adjusting lever to back and move the driver's seat to a position which provides easy access to all foot and hand controls.

Shift lever(s) check

Check the shift lever(s) for looseness and operation for smooth.

Lifting lever, tilting lever and attachment lever check

Check the loading levers (for lift, tilt and optional attachment) for looseness and smooth operation.

Increase the rotate speed of engine, make certain that the lifting lever, tilting lever and attachment lever in good work condition.

Instruments and sensors

Make sure that hour meter, water temperature indicator, oil temperature indicator, transmission fluid sensor and fuel sensor etc., properly.

7) Brake pedal, inching pedal and clutch pedal check

Drive truck slowly, press down brake pedal, and brake lamp lights.

Drive truck slowly, press down inching pedal, the speed of truck becoming decrease, and press downward more, truck will be braked and stop

Check function of clutch pedal, see Page 6 Controls, Pedal 《clutch pedal》。

Tire pressure

Turn the tire valve cap counter clock-wise and move it. Using a tire pressure gauge, measure the inflation pressure, and adjusting it to the specified pressure, if needed. After making sure there is no air leakage from the tire valve, reinstall the cap. Check that each tire does not get damaged at the tread surface or side face or bending at the rim.

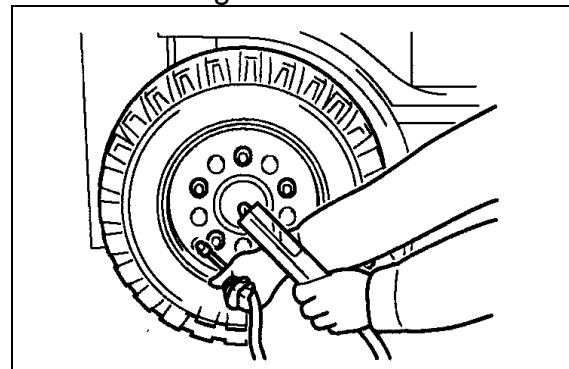

Warning!

Since the forklift truck needs tires that have a high inflation pressure to carry heavy loads, even a small bending of rims or damage at the tread surface could cause an accident.

Warning!

When using an air compressor, first adjust the air pressure of the compressor. Failure to do so will cause a serious accident, since the compressor delivers the maximum

pressure.

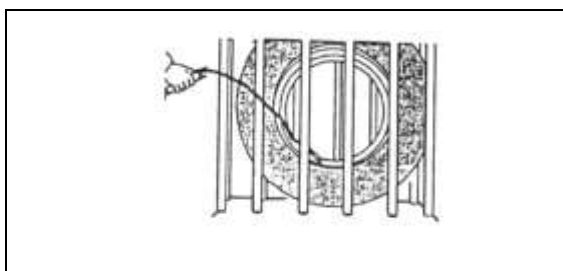

⚠ Warning

All nuts and bolts should be properly installed and tighten before inflating tire and rim assembly. An inflated tire contains potentially explosive energy. Don't over inflate.

Tire pressure GB/T2982-2001:

Truck type	Driving wheels (Front wheel)	Turning wheels (Rear wheel)
1t-1.8t	790kPa	1000kPa
2t-2.5t	860kPa	860kPa
3t-3.5t	830kPa	790kPa

Weekly maintenance (40 hours)

Increase the below content base on maintain daily.

1) Air cleaner

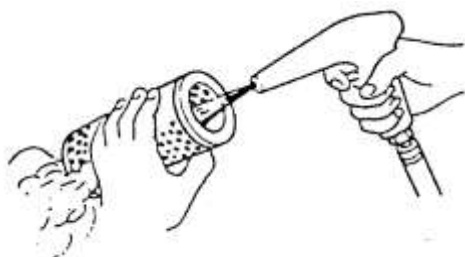

Please maintain the air cleaner when truck works 50-250 hours.

After six times, please change air cleaner.

Note: If the working condition is bad, the cycle of maintain and change air cleaner need more frequency.

The badly work condition with dust, the cycle of maintain and change air cleaner will be short. Advice maintains one time between 8-50 hours; change it between 100-300 hours.

Maintain method:

1. Take apart the cover of air cleaner.
2. Take out air cleaner.
3. Clean the inside or outside of dust by compress air.

! Caution:

- 1、 Please wear defend glass to avoid the dust fly up into your eyes.
- 2、 It will damage the engine if not maintain and change air cleaner on time.

2) Fan belt tension check



Stop the engine.

Use finger to press the belts at the midway between the water pump pulley and the generator pulley by 10kg press, and check the drop distance if is up to standard.

Engine	Drop distance (mm)
TD27AA	New 9-11, old 11-13
ISUZU C240	8-12
K21, K25	11-13
4TNE92 4TNE98	New 8-12, old 10-14
BY491GP	New 5-7, old 7-8

The latest parameters please see takes engine manual parameters shall prevail.

Warning!

If the belt has already been pulled long, cut out or has no surplus, it should be changed.

If the engine is still running, it's not permitted to carry on this check avoiding fingers or sleeves being caught up in.

3) Power shift transmission fluid level

Open the inspections cover and remove the filler cap. Inspect the lever gauge to make sure that the fluid level is on the upper mark of the gauge.

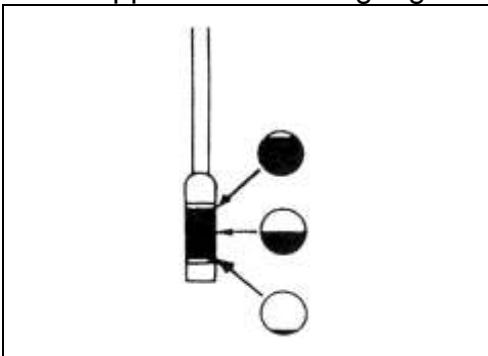

4) Mast and forks

Check the mast and forks to make sure:

①There is no crack and bend on the forks, and the forks are installed on the fork bracket strongly.

②Check if there have leakage of oil cylinder and tubing.

③Check the rollers' rotation.

④Check the mast if there have crack and bend.

⑤Operate the lever of lifting, tilting and attachment, check the mast if it's in good condition, and pay attention to system operating sound.

5) Lift chain tension check

①Raise the fork about 10cm-15 cm above the ground and make it vertical.

②Press middle of the chain by thumb. Make certain the tension for the right and left chains are even.

③Adjust the tension: Loosen the lock nut 1, screw the nut 2 and adjust the chain to make the equal tension, turning the adjusting nut 1 of the chain anchor pin.

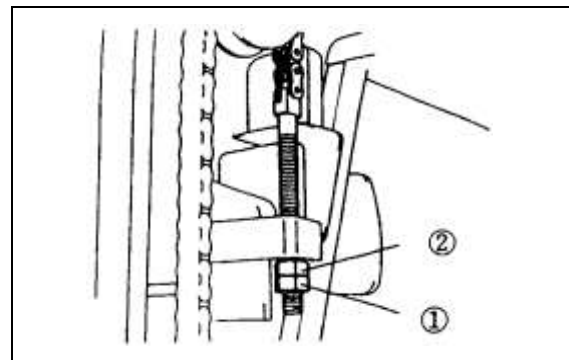
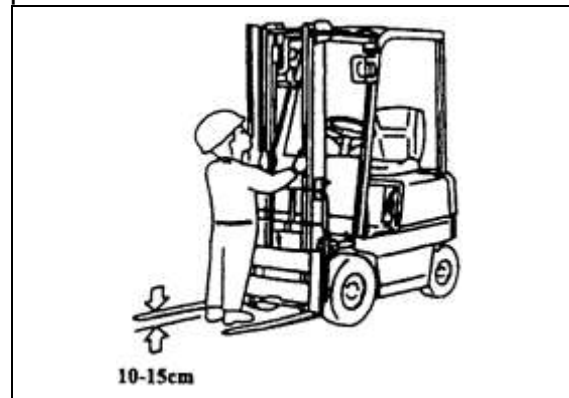

6) Lubrication of mast

Lubrication here on schedule, refers to figure as below:

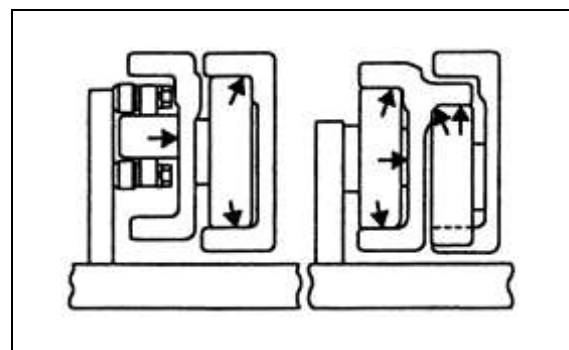

Mast

Paint lubrication grease on the slide support.

Note:

a). The periods of paint lubrication grease depend on the truck's work condition. If works heavy, please paint much more grease on mast.

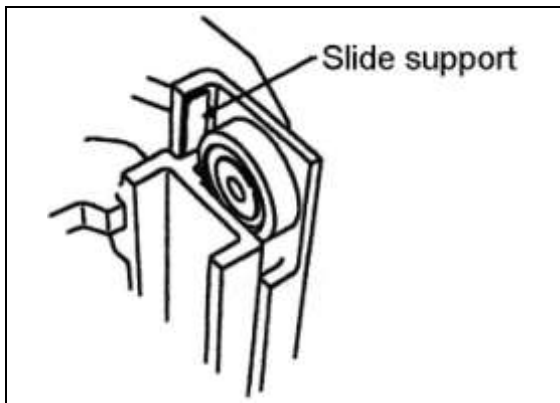

b). To assort with the truck's operation, paint some lubrication grease on the surface where the idler pulley and inside and outside masts touches.

Caution

Paint some lubrication grease; put the truck stop on a smooth road, engine flameout and tight hand brake. Prevent hand or body is clamped, and prevents falling off from high place. Keep safe.

7) Chain Lubrication

Take one brush with engine oil paint two sides on chain.

8) Lubrication grease to below parts, the detail please see <<Lubrication system drawing >>

- (1) mast bear lubricate
- (2) Brake pedal(clutch type) lubricate
- (3) Inching pedal(tor-con type) lubricate
- (4) Steering axle shaft lubricate
- (5) Steering knuckle main bearing lubricate
- (6) Steering rod bar pin lubricate
- (7) Steering cylinder pin lubricate

9) Bolt, nut tighten

Reference the <<Maintain cycle chart>>

10) Hub nut torque check

Check hub nuts should be tightened to the specified torque securely.

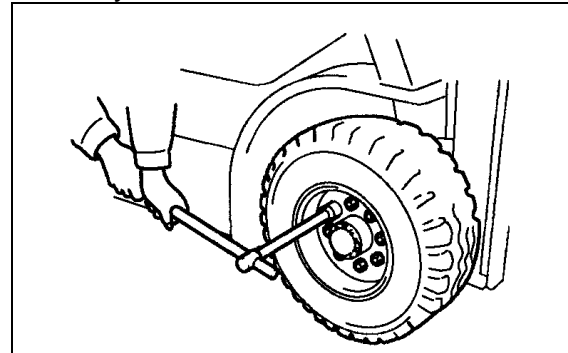

Driving wheel (front wheel)

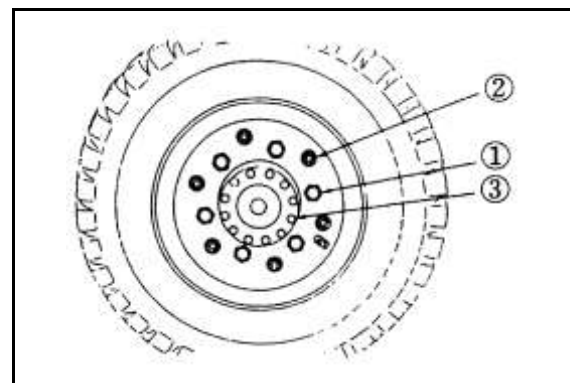

- ①. Hub nut
- ②. Divided rim bolt (only for 1ton-1.8 ton)
- ③. Drive shaft bolt

Specified torque N.m

	1t-1.8t	2t-3.5t
Hub nut	157-176	441-588

Turning wheel (rear wheel)

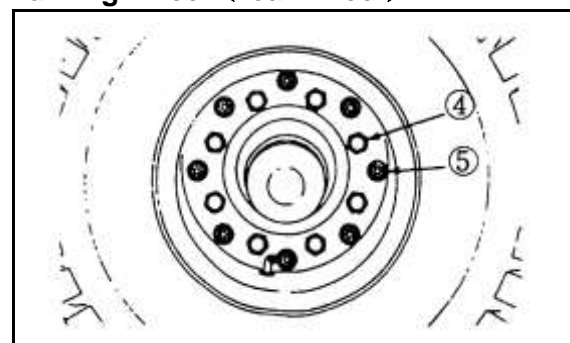

④. Rear hub nut

Specified torque N.m

	1t-3.5t
Hub nut	157-176

⑤. Divided rim bolt

11) Brake pedal, inching pedal and clutch pedal check

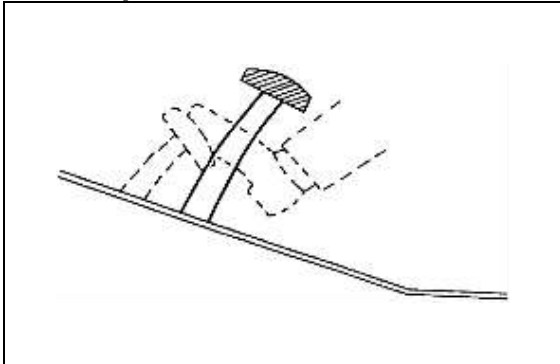

Press the brake pedal fully when the engine is running, the distance between brake pedal and front soleplate should be more than 60 mm.

Check the inching pedal and clutch pedal through the same method.

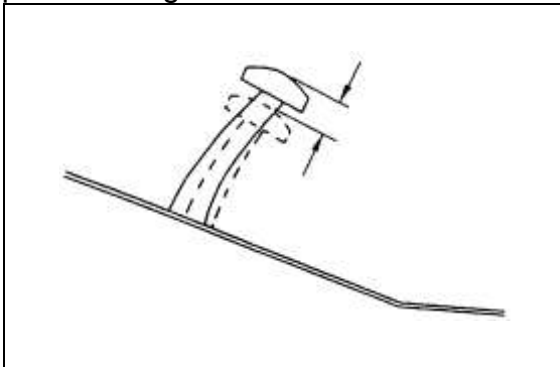

Height and the free clearance H:

	Free height	Press height	free clearance
Brake pedal	120-130	≥60	1-3
Inching pedal	120-130	≥60	touching bolt of inching pedal – brake pedal: ①0.9-3.4mm (NRW15A, QNRW22A) ②0

			mm(besides NRW15A, QNRW22A)
Clutch pedal	120-130	≥60	2-5

Notice :QN-RW22A is the shortening of CPQD20/25/30/35N-RW22A、RW15A is shorteningCPCD20/25/30/35N-RW15A.

Maintain monthly (166 hours)

Increase the below content base on maintain per week.

1. Change engine oil and oil filter

- 1) Start the engine, warm-up enough, then flameout.
- 2) Take out the oil cover and bottom shell to plug, release the oil.

Caution

Be careful about the hot oil.

·Milky oil shows there is some cooling fluid in it, find out the reason and revise.

·Oil is very rare show that the oil contains gasoline.

- 3) Wipe up and fit tuck and gasket.Screws down moment of oil tuck:29 N·m~39 N·m
- 4) Dismantle the oil filter by tool.

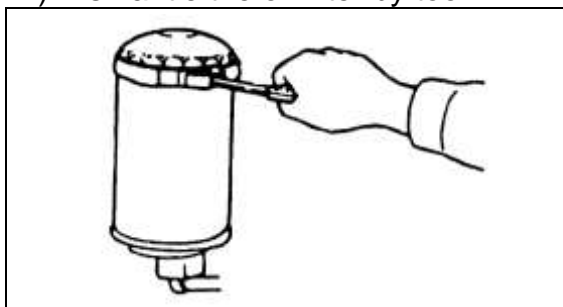

- 5) Use cloth clean the surface of oil filter.
- 6) Lay on little oil on the rubber ring of new oil filter.

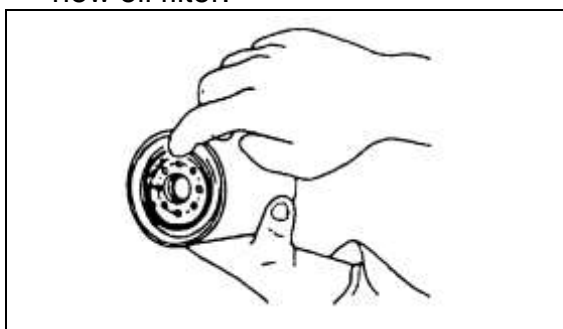

- 7) Install new oil filter by hand,not spanner.
- 8)Reference <<Table for the oil used in the truck>>,oil preferred.

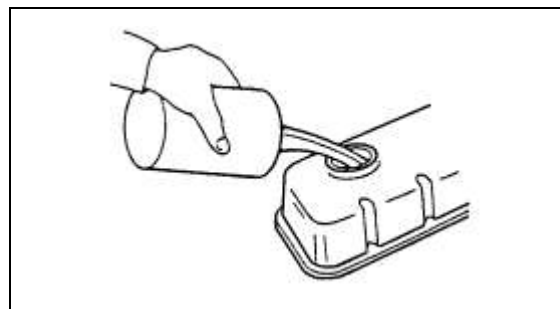

- 9)Start the engine,check leak oil around oil tuck and filter.

If leak obviously,this part is wrong install.

- 7) Warm-up engine enough,then flameout,check oil level later.fill if need.

Check the oil fluid surface,put the truck at ground flatly.

2.Plus lubricate to front and rear of pin roll of Tilt cylinder

Clean the plus place,pile out the past oil.

3.Check the gear oil of drive Axle housing

If there is more dust at work place, after 200 hours use, it need consider that change the gear oil of drive axle housing.

4. Change transmission oil filter **Check the hydraulic transmission oil fluid, if more dust, change the hydraulic oil of transmission. It is first time.**

Let the truck at level ground, play-down the fork to floor, inclined back the mast, strain brake handle, when transmission is at neutral position, engine is cut off.

Caution

Hot hydraulic oil and part will hurt Body. Do not touch the hot hydraulic oil and part.

- 1) Dismantle rubber mat and front soleplate.

- 2) Dismantle filter, deal with located statute.
- 3) Clean pedestal of filter, confirm that the old gasket of pedestal have be cleaned.
- 4) Plus less hydraulic oil on the new filter gasket.
- 5) Install filter by hand. When the filter get to pedestal, screw down 1/2-3/4 laps.

5.Change hydraulic transmission oil(first time, then semiannually)

Let the truck at level ground, play-down the fork to floor, inclined back the mast, strain brake handle. When transmission is at neutral position, engine is cutoff.

Caution

Hot hydraulic oil and part will hurt Body. Do not touch the hot hydraulic oil and part.

- 1) Put one case(cubage is over 20 litre) under the transmission.
- 2) Dismantle oil tuck,put oil in it.
- 3) Clean oil tuck then install.
- 4) Take out the dipstick.Add hydraulic oil.See <<Table for the oil used in the truck>>.
- 5) Startup engine.
- 6) Step on the brake pedal,operate the engine,let the transmission at state of go forward and backpedal so that the oil is in clutch.
- 7) Let the transmission at neutral,strain hand brake.
- 8) Take out the dipstick,inspect fluid position.
- 9) If oil is not enough,add oil to keep it between max and mix graduation.
- 10) Check the filter and oil tuck if leakage.
- 11) Flameout engine,install front soleplate.

6. Air-bleeding fuel system Diesel

During add fuel or discharge water from sedimentor, it's also need to bleed air in the fuel system.

- ①Loosen the bleed plug

②press the priming pump until fuel coming through the bleed plug contains no bubble.

- ③Fasten the bleed plug.

7. Water discharge from sedimentor (W10、W15A、W32、W33Diesel truck.)

When the sedimentor indicator lamp lights up, it means need water discharge.

- ① Put a container under the fuel filter。
- ② Loosen away the drain bolt (W15A) , then loosen the drain plug by turning 4 to 5 turns to dewater.
- ③ Fasten the drain bolt (W15A) and plug after the water was discharged.

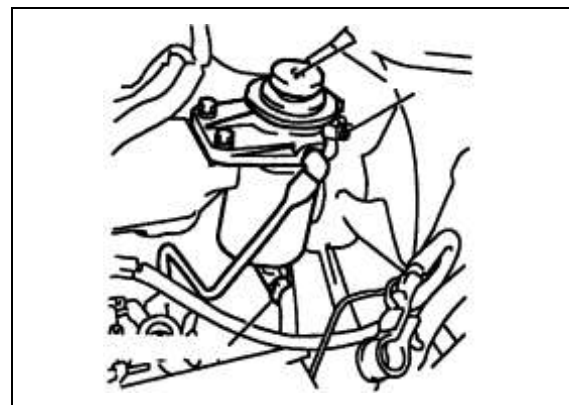

8 Exhaust gas check

Colorless	Normal: complete combustion
Black	Abnormal: incomplete combustion
White	Abnormal: water come in the burnt house
Blue	Abnormal: oil burns

Warning!

Don't start the lift truck in bad ventilation space. There is carbon monoxide in the exhaust gas, it is very dangerous

Maintain semiannually (1000 hours)

Increase the below content base on maintain monthly.

1.. Brake oil fluid change

- 1) Let the truck at level ground, play-down the fork to floor, inclined back the mast, strain brake handle. When transmission is at neutral position, engine is cutoff.
- 2) Pick off the rubber dustproof cap of oil orifice, install the both sides of preliminary clarity tube to oil orifice and waste oil collect bottle, then use spanner loosen oil orifice bolt counterclockwise. The other people step on the brake pedal repeat on the truck at same time. Here the brake oil will burst forth from oil orifice, note the fluid lever of brake oil tank. Append new brake fluid when the lever fall. Screw down the bolt of oil orifice when oil clear.
- 3) The people step on brake pedal repeat at culmination, not loose, the other people loose oil orifice bolt, screw down it after brake oil gush completely. Then inform the first people loose. Repeat upwards operation till brake oil without air bladder. Note the fluid lever of brake oil tank. Append new brake fluid when the liquid drop.

Note:

Transmission system forklift from Korea: add brake fluid (Brake oil pot) is Mobil Delvac Hydraulic SAE10W. Other model: Caltex DOT3 or Choice HZY3 brake liquid (note add after factory)

Caution

Prevent dust, water into oil when add brake fluid. The brake fluid is venomousness, causticity, touch in case, and please wash clean.

2. Steering wheel locked device lubricate

Daub the lubricating grease on the steering wheel locked device.

3. Hydraulic oil change

Let the truck at level ground, play-down the fork to floor, inclined back the mast, strain brake handle. When transmission is at neutral position, engine is cutoff.

Caution

Hot hydraulic oil and part will hurt body. Do not touch the hot hydraulic oil and part.

- 1) Put one case(cubage is over 60 litre) under the hydraulic oil box.Dismantle the oil tuck,let the hydraulic to case.
- 2) Dismantle hydraulic dipstick and fuel box cover discreteness.
- 3) Take out the magnet from oil box to clean and rinse the oil orifice of box bottom by hydraulic oil.
- 4) Clean and install the oil plug.
- 5) Fill hydraulic oil box.Reference <<Table for the oil used in the truck>>.
- 6) Startup the engine and operate multiple valve joy stick and turn system,fill hydraulic oil in all system.
- 7) Check each hydraulic component and pipeline if leakage oil.
- 8) Close the engine,retract all cylinder pole,check the oil level of hydraulic oil box.Add oil at graduation position.

4. Check clean and change hydraulic return oil filter, respirator and strainer

Let the truck at level ground, play-down the fork to floor, inclined back the mast, strain brake handle. When transmission is at neutral position, engine is cutoff.

- 1) Loose the bolt of hydraulic oil box cover board discreteness.
- 2) Take out return oil filter from top cover board.
- 3) Install new filter by hand.

- 4) Take out the strainer from oil box.
- 5) Install new filter by hand.
- 6) Install oil box top cover board and screw down bolt.
- 7) Take out respirator.
- 8) Clean by lotion and desiccation.
- 9) Install respirator.
- 10) Startup the engine and operate hydraulic system, let hydraulic oil in all system. Check leakage.
- 11) Close the engine, retract all cylinder pole, check the oil level of hydraulic oil box. Add oil at graduation position.

5. Change hydraulic transmission oil

Refer to 'Change hydraulic transmission oil' from 'Maintain monthly'.

6. Check, clean, change fuel filter

Note:

In the dust and dirty work condition, clean fuel filters per one month and changes per six months.

1. Take out the fuel filter discreteness.
2. Take out transducer form it.
3. Before install new one, install transducer discreteness existing, put a little fuel on the filter airproof.

Note

Before install, prohibit add fuel to filter, otherwise accelerate the abrasion of fuel system parts.

4. Install new filter discreteness.
5. Turn the new filter till the airproof mat adhibit to surface.
6. Screw down 2/3 loops.

Maintain annually (2000 hours)
Increase the below content base on
maintain semiannually.

1. Replace the engine cooling fluid

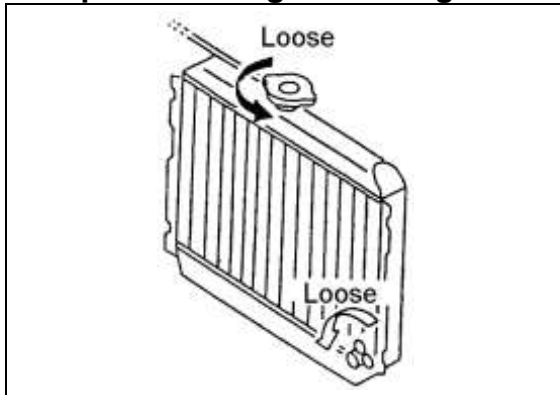

- 1) .Open the radiator cover and loosen the drain cover, let the oil flow out, then wash the cooling system.
- 2) . Screw down the drain cover.
- 3) . Add cooling fluid to radiator up to way out.
- 4) . Let the engine run fully.
- 5) . Stop the engine, after cool down fully, still add cooling fluid to radiator up to way out, and add cooling fluid to coolant reservoir "MAX" position.
- 6) .Check the drain cover if leakage.

⚠ Warning!

When the water temperature of the engine higher than 70 degree, please do not open the pressure cap of the radiator avoiding scald.

The engine cooling fluid is prevent rust and frostbite. See <<Table for the oil used in the truck>>.

2. Front-wheel bear change lubricate grease

Reference<<Maintain manual>>drive wheel hub,dismantle wheel hub.

3. Front-wheel bear change lubricate grease

Reference<<Maintain manual>>steering axle content.

4. Change steering axle gear oil

Let the truck at level ground. At neutral, engine flameout.

1. Take out the oil plug, put oil to a case. Clean oil plug.
2. Install oil plug.
3. Take out breathe freely plug and oil fluid position plug. Put the oil from orifice bend to steering axle shell until oil overflow from level plug. See add mete anew.
4. Press level and bend plug.
5. Start-up forklift. Movement the engine let the steering wheel control handle at neutral.
6. Take out level plug. Keep oil level until overflow.

Other

1. Fuse and relay

The fuse box is at middle of instrument and nearside of steering wheel. Before replace a new one fuse, please find out the cause of problem at first.

Please replace the same capacity fuse.

See “fuse and relay” on page 16.

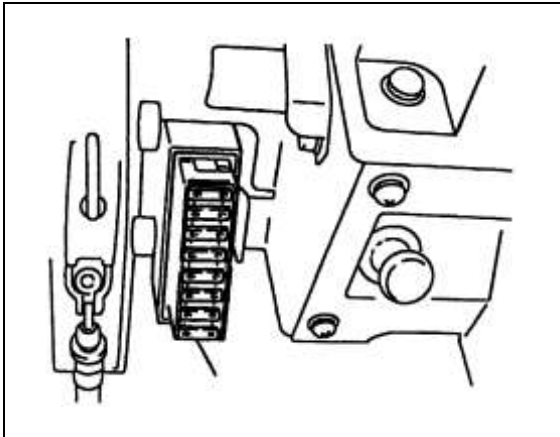

2. The change of tyre

Warning!

When using an air compressor, first adjust the air pressure of the compressor. Failure to do so will cause a serious accident, since the compressor delivers the maximum pressure.

To make sure safe, put the tyre in a defend casing when charge.

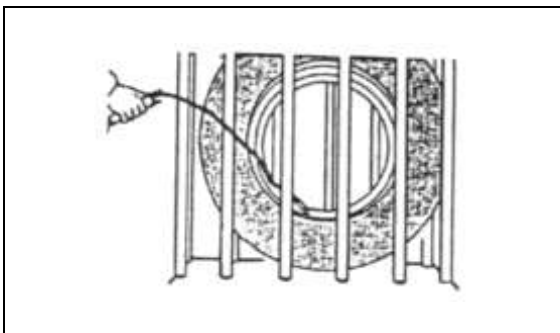

Front wheel

- 1) Place lift truck on level concrete.
- 2) Start engine and raise carriage about 100mm height.

- 3) Place chocks behind rear wheels to prevent movement of forklift.
- 4) Loosen wheel nuts 1-2 turns each by turning them counter-clockwise.
- 5) Tilt mast fully backward, and place a wooden block under each side of outer mast.
- 6) Tilt mast forward until front tires are raised from surface.

Caution:

Do not allow loose nuts before the front wheels leave away from the ground.

- 7) Support forklift truck by putting additional wooden blocks under each side of the front-end frame as shown below. Stop the engine.
- 8) Take out the wheel nut and replace the front wheel tire.

Warning

- a. When removing tire from wheel rim, do not remove rim set bolts and nuts before releasing air.
- b. Make sure that wooden blocks used to support lift truck are solid, one-piece units
- c. Never get under forklift while it is supported only by wooden blocks.

- 9) Retighten the wheel nut temporarily.
- 10) Start the engine, and take out the wooden block.
- 11) Tilting backward the mast and lower down the mast slowly, then take out the wooden block under the outer mast and rear wheel.
- 12) Retighten the wheel nut with right tightens torque.
- 13) Inflation tyre again to right air pressure.

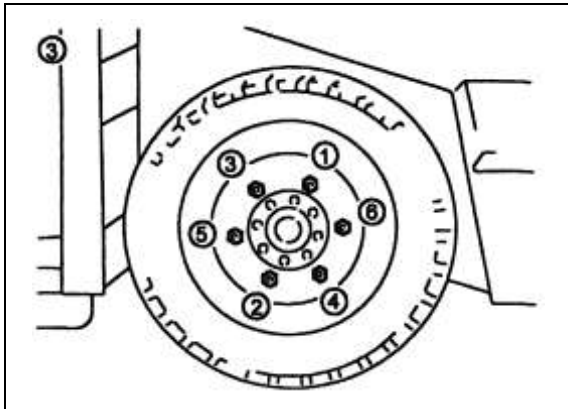
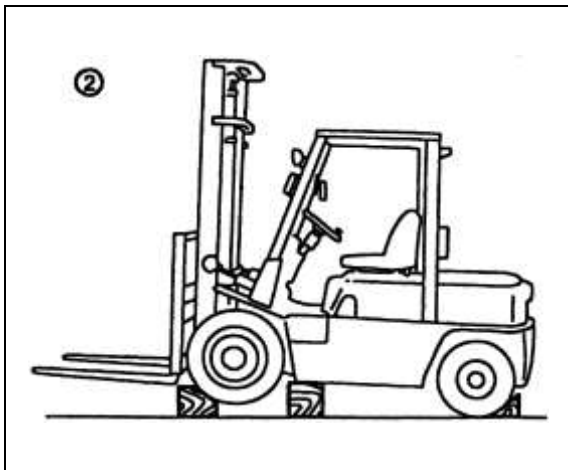
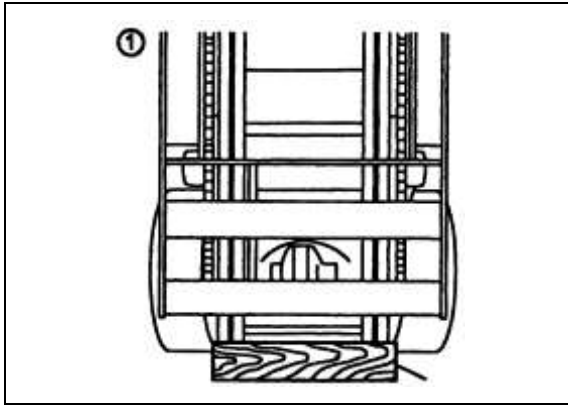

Rear wheel

- 1) Place lift truck on level concrete.
- 2) Pull the parking brake lever and place chocks before front wheels to prevent movement of forklift.
- 3) Put the lifting jack under the counterweight.

Caution:

Make sure the jack capacity is bigger than 2/3 of service weight of forklift.

- 4) Loosen wheel nuts 1-2 turns each by turning them counter-clockwise.

Warning!

Do not move wheel nuts until rear tires are raised from ground.

- 5) Raise the forklift by swing the rod of jack until it is out of ground. Support forklift truck by putting additional wooden blocks under each side of the front-end frame as shown below.

- 6) Take out the wheel nut of rear wheel, and then replace the wheel.

Warning!

- a. When removing tire from wheel rim, do not remove rim set bolts and nuts before releasing air.
- b. Make sure that wooden blocks used to support lift truck are solid, one-piece units.
- c. Never get under forklift while it is supported only by wooden blocks.

- 7) Retighten the nut on consequence as figure show below:

- 8) Remove the wooden block under chassis body. Let down the forklift slowly. Then take away the chocks before the front wheel.

- 9) Retighten the wheel nut with right tightens torque.

- 10) Inflation tyre again to right air pressure.

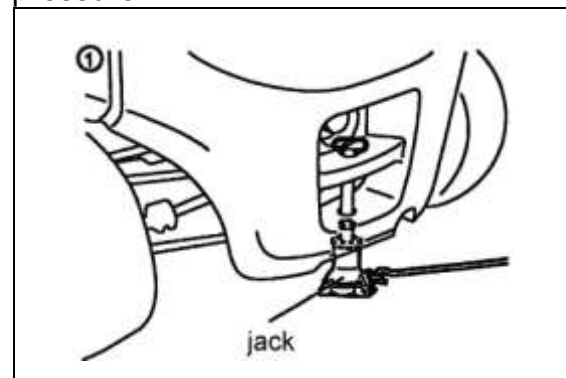

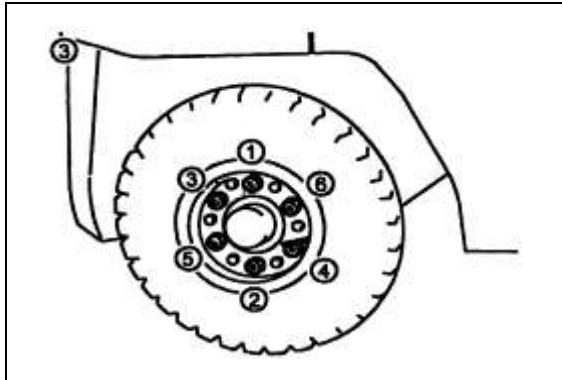
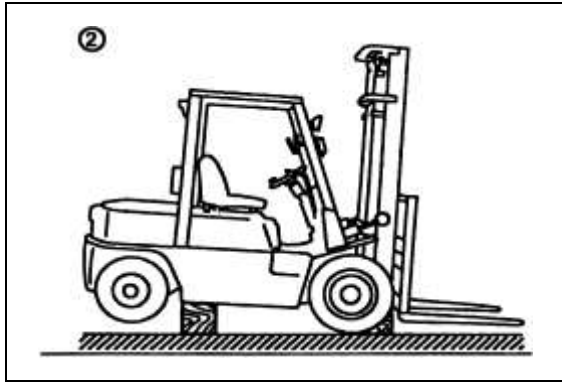

3. The measure for cold and hot

Base on the temperature, choose the suitable viscosity oil.

4. Clean the radiator and radiation fin

Caution

The dust may fly to your eyes, so you'd better wear your glasses to protect your eyes.

If the radiation fin is build up, it will lead over hot, so use compress air, vapour or water.

Caution

Clean the radiation fin by compress air or vapour, put the muzzle to radiator a right angle.

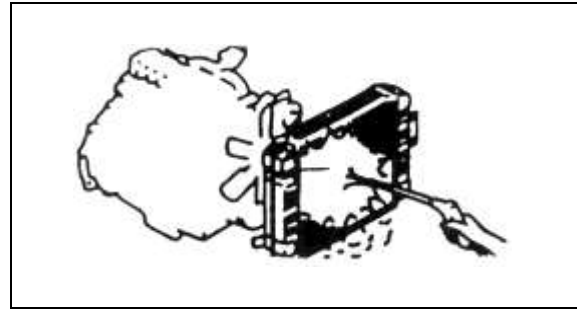

5. The operation of engine too hot

If the engine is too hot, do not stop it at once, do it as follow:

- ① Movement engine low speed;
- ② Open the engine cover to airiness
- ③ Stop when water temperature fall;
- ④ Check the cooling fluid, add water, if need.

5. Structure and stability of truck

It is very important for operator to know the truck's structure and relationship between load and stability.

Caution The structure of the truck

The basic structure of the truck is mast (include mast and forks) and body (include tire).

The lift truck keeps the balance of weight between the truck body and the load on the forks with the center of the front wheels as a fulcrum when the rated capacity load is placed in position.

Due care should be paid to the weight and the center of gravity of loads to maintain the stability of the truck.

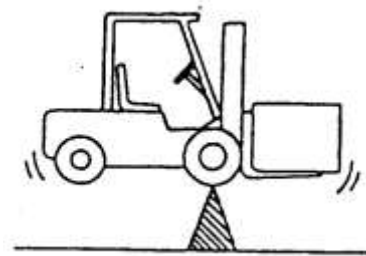

Caution Load center

There is difference because of the loads' shape, gravity, such as box, board and large roller. It is very important to distinguish the difference and the gravity center of loads.

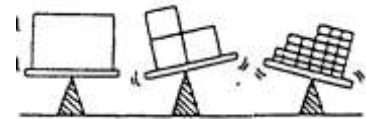

Warning!

If the truck is going to turn over, do not attempt to get out of the truck, because the speed of overturn is much fast than you. You should hold the steering wheel, and this practice will let you in the seats. Please tie safety belt.



Caution Gravity and stability

The combined center that is composed of the barycenter and the load center determine the stability of lift trucks.

When unloaded, the barycenter does not change;

When loaded, the barycenter is determined by the truck and the load's center.

The barycenter is also determined by the tilting and lifting of the mast.

The combined center is determined by these factors:

- Load's size, weight and shape.
- The lifting height.
- The tilting angle.
- The pressure of the tire.
- The radius of turning.
- The road and grade's angle.
- The attachments.

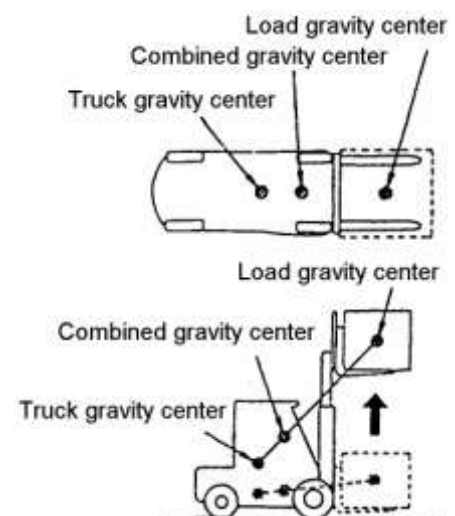

Caution the stability zone of the barycenter

In order to make the truck stable, the combined center must be in the triangle which is made up of two points that the two front wheels attach ground and the midpoint of the back driving axle.

If the combined center is in the front driving axle, the two front wheels become two fulcrums, the truck will overturn. If the combined center departs the triangle, the trucks shall overturn in the corresponding direction.

Stability zone

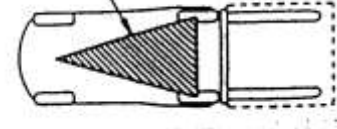

Caution the max load

The distance between the load center and the front surface of forklift or load bracket (select the min) on the forklift is called

LOAD CENTER DISTANCE. The max gravity that the truck can load is called MAX LOAD on condition that the load is on the load center distance. The relationship of MAX LOAD and LOAD CENTER DISTANCE is specified on the load capability chart. If the load center is moved near the front of forklift, the load should be cut down.

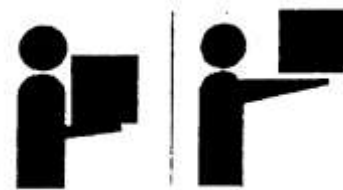

Caution the load capability chart

This chart shows the relationship of MAX LOAD And the location of LOAD CENTER DISTANCE. Check whether the load and load center distance is in the range referred by the chart. Put the most important parts near the load bracket if the shape of goods is complex.

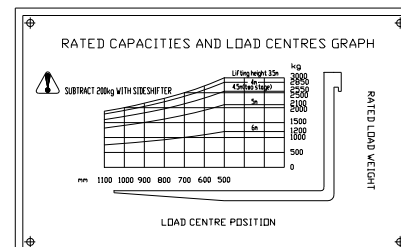

Caution speed and acceleration

A static object keep its static station which is not affected by outside force, one dynamic object moves with the same speed which is not affected by outside force, this is inertia.

Because of inertia, one force affected backward when the truck is moving , one force affected forward when the truck is stopping.

It is very dangerous to press the brake suddenly. It may result in capsial or sliding down of the load because of huge force to the front.

Centrifugal force will be formed during turning and its direction is from the turning center to the outer. The force may result in the capsial of truck. Right-and-left stable zone is very small, so the truck's speed must be reduced when turning to prevent capsial. If the truck conveys the load which is on the high location, feasibility of capsial is very big.

6. Operation

Warning!

Before operating the truck, check all controls and warning devices for proper operation. If any damage or fault is found, don't operate truck until corrected.

Star-up

Starting diesel engine

Make sure that the shift lever(s) and loading levers are in neutral and hold position.

Turn the ignition switch to ON position after turning the ignition switch to START position.

Caution

If you can not start the engine in 5 seconds, should switch to OFF, after 2 minutes then start it again.

If you can not start the engine 3 times continuously should check the truck to the core.

Caution

If the temperature is lower than -5 degree, Turn the key to "ON (|)" position and the indicator lights up for a moment. After the indicator goes out, turn the key to "Start  " position.

Starting gasoline engine

Make sure that the shift lever(s) and loading levers are in neutral and hold position.

Cold engine.

Pull out the choke button fully. Depress the accelerator pedal to the floor two or three times and release it. With your foot OFF the pedal, crank the engine by turning the ignition key to "START". Release key when engine starts.

Warm engine

Do not pull out the choke button.

Press down the accelerator pedal halfway and cold. Crank the engine by turning the ignition key to "START". Release key when engine starts.

Caution

Do not press down the accelerator pedal fully when starting warm engine. This operation may harden the engine starting. Pressing down the accelerator pedal several times will cause harder starting.

Caution

The starting time should less than 5 seconds a time, the interval between two starting should much than 2 minutes.

After engine has started

Warm up the engine (for about 5 minutes)

Check the rotation (sound or gear) of the engine.

Caution

Diesel model

After starring up the engine, accelerate it's speed to the arrange of 1800r/min-2000r/min, and warm it without work.

Gas model

After cranking the engine, push in the choke button step by step observing the warm-up condition and stability of speed of the engine. Push in the choke button fully after making sure the engine is completely warmed up.

·Check the combustion (or misfiring) sound.

·Check the condition (density) of exhaust.

·Make sure that all the warming lamps are off.

·After thoroughly warming up the engine, operate the loading levers 2 to 3 times in their full stroke and check their working conditions.

Traveling

Hold the knob on the steering wheel with your left hand and get the right hand ready for loading working, lightly putting it on the wheel.

Set the bottom of the fork 15 cm to 20 cm above the ground and fully tilt back the upright.



Check the safety around the machine and give a signal when starting the engine.

Clutch type

- Depress the clutch pedal and engage the shift levers.
- Release the parking brake lever.
- Gradually release the clutch pedal while depressing the accelerator pedal to start the machine.

Caution

Do not rest your foot on the clutch pedal while you are driving.

Torque converter type

- Depress brake pedal and engage the forward-reverse lever.
- Release the parking brake lever.
- Release brake pedal and depress the accelerator pedal to start the machine.

Gear shifting

Clutch type machines

- Always stop the truck before reversing the direction of travel.
- When gear shifting from high to low speed or vice versa, once increase the engine speed and release accelerator pedal. At the same time, press the clutch pedal while shifting the shift lever into the desired position. Then press

the accelerator pedal while releasing the clutch pedal.

Torque converter type machines

- Always stop the truck before reversing the direction of travel.
- Shift the shifting lever.

Slow down

Clutch type machines

Since the machine uses the synchromesh transmission, it is not necessary to perform the double clutch operation. Remove your foot from the accelerator pedal, press the clutch pedal to the full, place the speed shift lever into the “first speed” position, and press the accelerator pedal while releasing the clutch pedal.

Torque converter type machines

Release accelerator pedal depression a little, and press the brake pedal, if needed.

Steering

Unlike general passenger-cars, the steer wheels are located at the rear of the truck. These cause the rear of the truck to swing out when a turn is made.

Slow down the truck and move toward the side to which you are turning. The steer hand wheel should be turned a bit earlier than as with the front wheel steering car.

Stopping or parking the truck

1. Slow down and press the brake pedal to stop the truck (in the case of clutch type machine, the clutch pedal is used).
2. Place the shift lever in neutral.
3. Apply the parking brake by pulling up on the parking brake lever.
4. Down the forks on the ground, and tilt the mast forward maximum.
5. Place the key switch in “OFF” to shut down the engine. In the case of the diesel truck, pull out the engine stop button. Remove the key and keep it.

Caution

- Don't dismount from the moving machine
- Never jump off the machine.

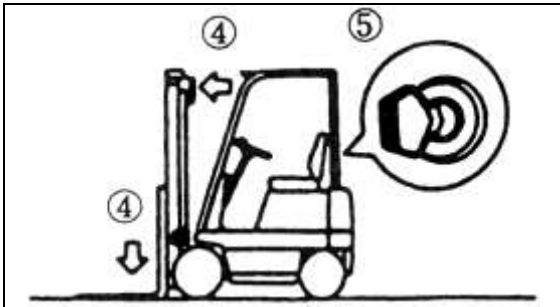

Pick up

- The forks should be adjusted sidewise to maintain proper balance of load.
- Place the machine right in front of the load to be handled.
- The pallet should be evenly positioned across both forks.
- Insert forks into the pallet as far as possible.
- To raise loads from the ground.

First lift the forks 5cm to 10 cm off the ground or floor and make sure loads rest stable.

Then, tilt the mast backwards fully and lift forks up to 15cm to 20 cm off ground then start running.

- When handling bulky loads which restrict your vision, operate the truck in reverse except when climbing grades.

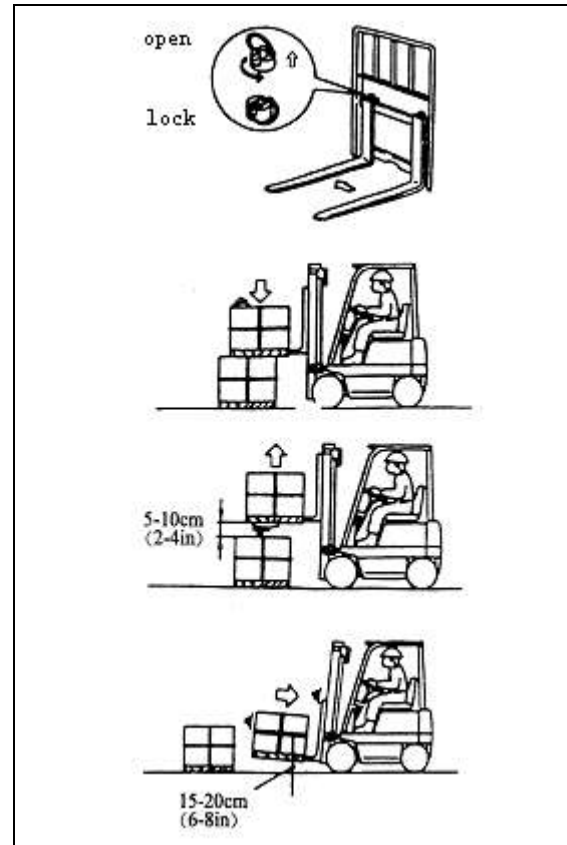

Stacking load

- When approaching the deposit area slow down your truck.
- Once stop the truck right in front of the area where your load is to be deposited.
- Check the condition of the deposit position.
- Tilt the mast forward until forks become horizontal. Raise forks until they are a little higher than the deposit position.
- Move forward to place the load directly over the desired area and stop the truck.
- Make sure your load is just over the desired area. Slowly lower the load into position. Make sure the load is securely stacked.
- Disengaged forks from the load by using necessary lift-tilt operation and then back away.
- After making sure the fork tips leave

the load, lower the forks to the basic position (15cm to 20 cm off the ground).

- Tilt the mast backwards.

Warning!

Never tilt the mast with loads upraised 2m or more.

Don't leave or dismount from the truck when the load is raising high.

Remove load

- When approaching the area where the load is to be retrieved, slow down your truck.
- Stop the truck in front of the load so that the distance between the load and fork tips is about 30 cm.
- Check the condition of the load.
- Tilt the mast forward until forks become horizontal. Elevate forks up to the position of the pallet or skid.
- Make sure forks are positioned properly for the pallet. Move forward slowly to insert forks into the pallet as far as possible and then stop the truck.

Caution

If the forks are hard to be fully inserted, use the following procedure: move forward and insert 3/4 of the forks. Raise the forks 5cm to 10 cm and move backward 10cm to 20 cm with the pallet or skid on the forks, then lower the pallet or skid on the stack. Move forward again to insert the forks fully.

- Raise the forks 5cm to 10 cm off the stack.
- Check all around the truck to insure that the path of travel is unobstructed and back away slowly.
- Lower forks to a height of 15cm to 20 cm above the ground. Tilt the mast backward fully and move to the desired area.

7. Deposit

Deposit daily

Park your truck on a level ground-preferably in a wide area. If parking on a slope is unavoidable, position the truck so that it cross the slope and block the wheels to prevent accidental roll.

Make sure the shift level on neutral position.

Pull the hand brake.

Shut down the engine and control the lift and tilt level several times so that the inner pressure in the hydraulic tube will decreased.

Take down the key and deposit it in a safe position.

Warning!

You should tell the manager if you find any failure about the truck, then repair it immediately.

Do the following things:

- ① Clean the oil and grease with cloth and water on the truck body.
- ② Check the whole situation of truck, especially the tyres.
- ③ Fill the oil tank with destined fuel.
- ④ Check whether the hydraulic oil, the engine oil, fuel and the cooling liquid are leakage.
- ⑤ Fill lubricate grease.
- ⑥ Check whether the junction plane between the nuts of wheel boss and the piston of hydro cylinder is loose, and whether the surface of piston has been pulled.
- ⑦ Check whether the wheels of mast roll stably.
- ⑧ Lift the lifting cylinder to the top and fill it with oil.
- ⑨ In cold weather, it needn't to discharge the antifreeze, but the cold water should be removed completely.

Deposit the truck for a long time

Deposit the truck for a long time, fill up the truck body and counter weight with block to reduce the load of the two rear wheels.

Warning!

- a. The block must be single and hard enough to support the truck.
- b. Don't use a block with high than 300 mm (11.81 inch) .
- c. Lift the truck to height of placing on the bearing block.
- d. Place two same size blocks under the left and right sides of the truck.
- e. After supporting the truck with block, swing the truck forward, backward, left and right, check its safety.

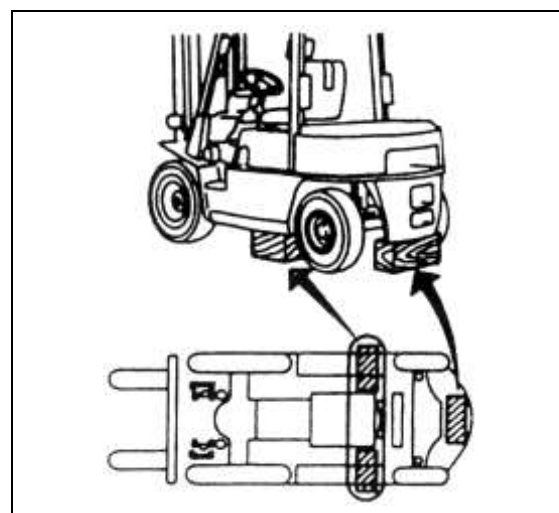

On the basic of the “deposit” you should do these checks and maintain additional:

1. Take down the battery and recharge it once a month, place it in the shade.
2. Brush antirust oil on those parts which is exposed such as piston rod and axle.
3. Put a cloth on vent-plug and air-cleaner.
4. Start the engine once a week. If the water has already been let out, add water in the radiator. Then start the fork lightly.
5. In summer, it is not recommendatory to park the fork on asphalt road.

Running after deposit for a long time

1. Get down the antirust oil from the exposed parts.
2. Vent the gear oil of the crankcase, driving axle, transmission box (clutch type), hydraulic transmission box (torque converter type) clear it and add with new gear oil.
3. Clean out dirty things and water in the hydraulic oil reservoir and fuel reservoir add with new hydraulic oil.
4. Check the clearance of the valve, gas valve cap and other parts on the engine.
5. Adding antifreeze or water to the required scale.
- 6 .Recharge the battery, then install on the truck.
7. Check others carefully such as start, running, turning, lifting etc.
8. Warm-up your truck

8. Maintenance

Preventive maintenance schedule

○— Check, revise, adjust

× — Replace

Note: (1) If the working place has much dust or other pollutions, the times of maintenance should be increased.

(2) If the parts are abnormal such as engine power descends, emit black smoke or noise increase before the replacing time is coming, it should be check. Sometime it needs to adjust diesel nozzle pressure and fuel atomization.

Note:

1. The fork lift truck needs inspection and maintenance termly, make it in good working condition.
2. Inspection and maintenance are usually ignored; you must find the problems and solve it in time.
3. Use the orthodoxy spare part of HANGZHOU fork lift truck general plant.
4. Don't use different oil when changing or adding oil.
5. Don't throw away the waste oil or electrolyte liquid as you wish. Should deal with it depend on the local environmental protection laws and regulations require.
6. Maintenance on schedule
7. After you make maintenance, you'd better make a record.
8. Forbid to repair the fork lift truck if you haven't been trained.

Counterbalance weight (unit: kg)

Model of truck	1t	1.5 t	1.8 t	2 t	2.5 t	3.0 t	3.5 t
Counterbalance weight	550	770	925	1192	1534	1780	2100

Checking Item	Service required	Tools	Monthly (166hrs)	Trimonthly (500 hrs)	Semiannually (1000 hrs)	Annually (2000hrs)
Engine	1. Check the valve clearance is correct	clearance gauge	○	○	○	○
	2. Fan belt tension check		○	○	○	○
	3. Retighten cylinder head bolt		○	○	○	○
	4. Clean the outface of radiator (1)		○	○	○	○
	5. Replace engine oil (1)		×	×	×	×
	6. Replace the oil cleaner (diesel engine) (1)		×	×	×	×
	7. Replace engine cooling fluid					×
	8. Clean the air cleaner element (gasoline engine)			×	×	×
	Replace the air cleaner element (diesel engine)		○	○	○	○
	9. Drain the water of oily water separator (diesel engine)		○	○	○	○
	10. Clean or replace the filter element of air cleaner		○	○	×	×
	11. Idling of engine	tachometer	○	○	○	○
	12. Ignition timing (gasoline engine)		○	○	○	○
	13. Spark plug (gasoline engine)		○	○	○	○
	14. Check distributor point, cover and rotor (gasoline engine) (1)		○	○	○	○
	15. Lining of distributor (IC ignition system) (1)					○
	16. Check fuel injector, adjust pressure (diesel engine) (2)			○	○	
	17. P. C. valve and pipe blocking or damage				○	○
18. Battery electrolyte check			○	○	○	○

Maintenance of chassis and body

Checking Item	Service required	Tools	Monthly (166hrs)	Trimonthly (500 hrs)	Semiannually (1000 hrs)	Annually (2000hrs)
Clutch	Check clutch pedal for free travel and clearance between pedal surface and floor when clutch is unlocked		○	○	○	○
	Release bearing lubricate			○	○	○
Mechanical Transmission	Check oil level, and replace it if needs		○	○	○	○
Torque Converter Transmission	Clean oil filter element				○	○
	Replace oil (1)		First timex		×	×
Driving axle (front axle)	Check differential oil, and replace it if needs		○	○	○	×
	Check connection and retighten moment		○	○	○	○
Brake and inching system	Check and adjust brake pedal for free travel and clearance		○	○	○	○
	Replace brake fluid				×	×
	Check for proper brake operation		○	○	○	○
	Check and inching brake pedal for free travel and clearance		○	○	○	○
Hydraulic system	Check for oil level, Change oil (1)				×	×
	Clean oil return suction strainer (1)				×	×
	Proper work of the hydraulic oil pump		○	○	○	○
	Proper work of control valve		○	○	○	○
	Check for oil leaks, looseness, collapse, deformation and damage		○	○	○	○
	Clean the hydraulic oil reservoir				○	○

Checking Item	Service required	Tools	Monthly (166hrs)	Trimonthly (500 hrs)	Semiannually (1000 hrs)	Annually (2000hrs)
Lifting system	Check chain for tension		○	○	○	○
	Lubrication of chains		○	○	○	○
	Check chain and bearing for damage or deformation		○	○	○	○
	Check lifting cylinders for proper operation and connection		○	○	○	○
	Check tilting cylinders for proper operation and connection		○	○	○	○
	Check for forks and stopper pins for damage or wear		○	○	○	○
	Check fork base and hook welding for defective cracks or wear		○	○	○	○
	Check roller of mast and lifting bracket parts for cracks or damage			○	○	○

Table for bolt's tight moment

unit: N•m

Bolt's diameter	Grade			
	4.6	5.6	6.6	8.8
6	4~5	5~7	6~8	9~12
8	10~12	12~15	14~18	22~29
10	20~25	25~31	29~39	44~58
12	35~44	44~54	49~64	76~107
14	54~69	69~88	83~98	121~162
16	88~108	108~137	127~157	189~252
18	118~147	147~186	176~216	260~347
20	167~206	206~265	245~314	369~492
22	225~284	284~343	343~431	502~669
24	294~370	370~441	441~539	638~850
27	441~519	539~686	637~784	933~1244

Note: • Use entirely 8.8 grade bolt in the important joint position.

• Bolt's grade can be found in the head of the table, if it can't be found, the grade is 8.8.

Periodic replacement of key safe parts

- Some parts can't be found damnification or mutilation though schedule maintenance.
In order to make sure the safety of truck, please replace these parts termly listed in following table. If there is any off-normal happened on these parts before replacement time, please replace it deservedly.

Name of key safe parts	service life (years)
Brake hose or hard tube	1~2
Hydraulic rubber hose for lifting system	1~2
Lifting chain	2~4
High pressure rubber hose or tube for hydraulic system	2
Grease cup for brake fluid	2~4
Tube for fuel	2
Sealing member, rubber articles inside of hydraulic system	2

Table for the oil used in the truck

Description	Shop sign, Code name	Capacity(L)	Remark
Gasoline	90	45	1t~1.8t
		60	2t~3.5t
Diesel	0# (summer) -10#~-35# (winter)	45	1t~1.8t
		60	2t~3.5t
Diesel Engine Oil	Besides winter : CD grade15W / 40, Winter : CD grade 10W / 30 Or according to engine maintenance manual(arctic-alpine :5W/30 CD or according to engine maintenance manual)	5	1t~1.8t
		6.5~7.5	2t~3.5t
Gasoline Engine Oil	Up DE grade 15W/40 Or according to engine maintenance manual(arctic-alpine :CALTEX API SAE 5W-30)	5	1t~1.8t
		6.5~7.5	2t~3.5t
Hydraulic Oil	L—HM32 (arctic-alpine: L—HV32)	35~40	1t~1.8t
		45~50	2t~3.5t
Hydrodynamic Power Transmission Oil	DEXRON—III (Caltex)	4~10	See the table below
Gear Oil	GL—5 85W/90	5.5	1t~1.8t
		8	2t~3.5t
	API GL—5 80W/90 (Caltex)	6.5	exclusive use
Brake Liquid	Choice HZY3 brake liquid (add when leaving factory) or DOT3 brake liquid	1.5	Except MS drive forklifts
	MobilDelvac advanced hydraulic oil SAE10W	1-1.5	MS drive forklifts
Antirust Antifreeze Liquid	-35# car antifreeze (add when leaving factory) or FD-2 antifreeze	10~11	
Industrial Vaseline	2#		Electrode of Storage battery
Lubrication Grease	Currency lithium group lubricate grease		

Remark : the 1t~3.5 t trucks have been added antirust antifreeze liquid, you need not discharge the liquid even at cold winter. Add the liquid according to original requirement if need. Replace the liquid every 2 years normally. If the truck has not been added antirust antifreeze liquid, users can add the liquid according to requirement. The cooling water must be discharged at winter if the truck has not been added antirust antifreeze liquid.

Hydrodynamic power transmission oil

Description	Shop sign, Code name	Capacity(L)	Remark
Hydrodynamic power transmission oil	DEXRON—III (Caltex)	6-8	CPQD10/15/18N-RW7, CPQD20/25N-RW7 CPQD30/35N-RW7, CPCD10/15/18N-RW10, CPCD20/25N-RW10, CPCD30/35N –RW10; CPQD10/15/18N-RW21, CPQD20/25N-RW22 CPQD30/35N-RW22, CPCD20/25N-RW27, CPCD30/35N-RW27, CPCD10/15/18N-RW32, CPCD20/25N-RW32, CPCD20/25N-RW33, CPCD30/35N-RW33, CPCD20/25N-RW15A CPCD30/35N-RW15A , CPQD20/25N-RW22A CPQD30/35N-RW22A, CPQD20/25/30/35N-RW26-Y
		10	CPCD10/15/18N-RW32M CPCD20/25N-RW32M CPCD20/25N-RW33M CPCD30/35N-RW33M
		4	CPCD20/25N-RW10B CPCD30/35N –RW10B CPQD20/25N-RW22B CPQD30/35N-RW22B CPCD20/25N-RW32B CPCD30/35N-RW33B Okamura drive forklifts, etc.

Lubrication system drawing

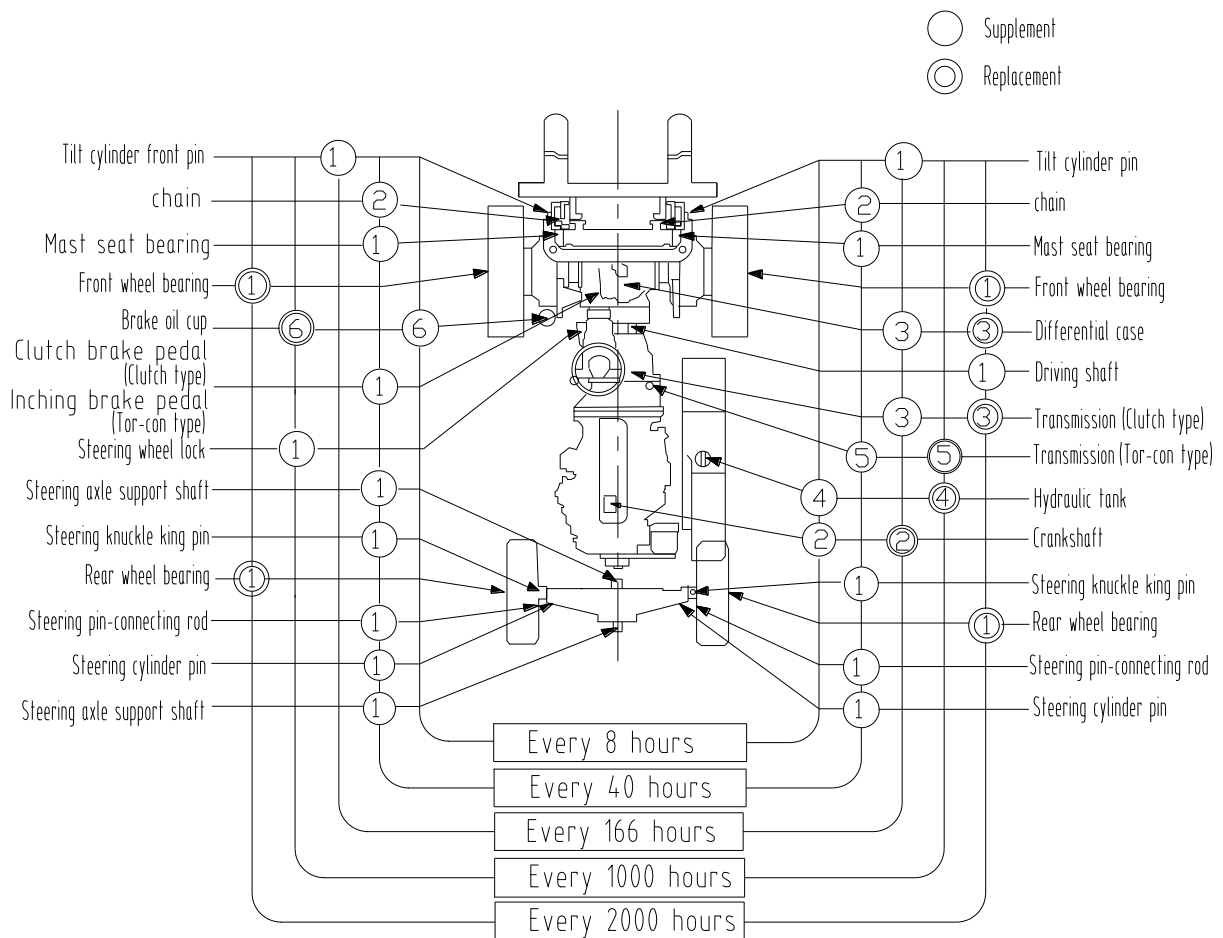

- | | |
|--|------------------------------|
| 1. General motors lithium Complex Grease | 2. Engine lubricating grease |
| 3. Gear oil | 4. Hydraulic oil |
| 5. Converterassy-torque oil | 6. Brake oil |

Notice:

- The detail of lubricating oil for different truck can refer to "Table for the oil used in the truck"
- Lubrication for mast, please see the 8 hour (daily or every shift) check .

Environment protection

- Please do the clean and maintenance of the truck at the specified spot.
- Before remove the pipe, connector and related parts, please use the specified container to contain the disused liquid (include antifreeze liquid, engine oil, hydraulic oil, hydrodynamic power transmission oil, gear oil, brake liquid, lubrication grease) and disused battery.
- The disused liquid referred above should be disposed according to the local environment protection law rather than pouring at discretion to pollute the environment.

Safety note: The antifreeze liquid, engine oil, hydraulic oil, hydrodynamic power transmission oil and gear oil should be replaced under 70 °C because the temperature will be high after long running, no touching with skin, or you will be scald or corroded.

Scutcheons

There are many scutcheons and labels on the different position of the truck.

Plug-in mast chain view from "D"

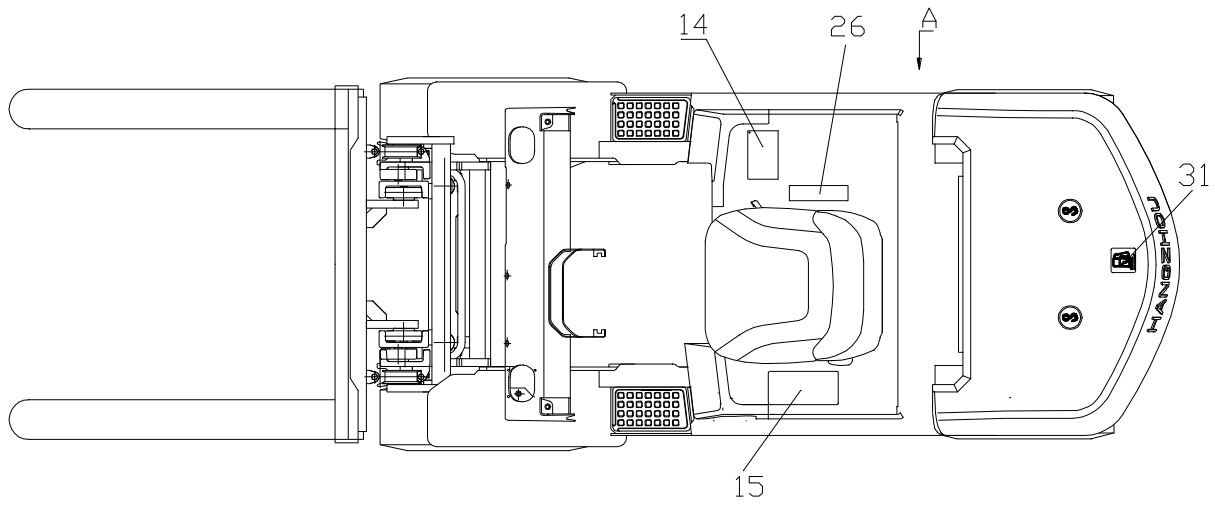
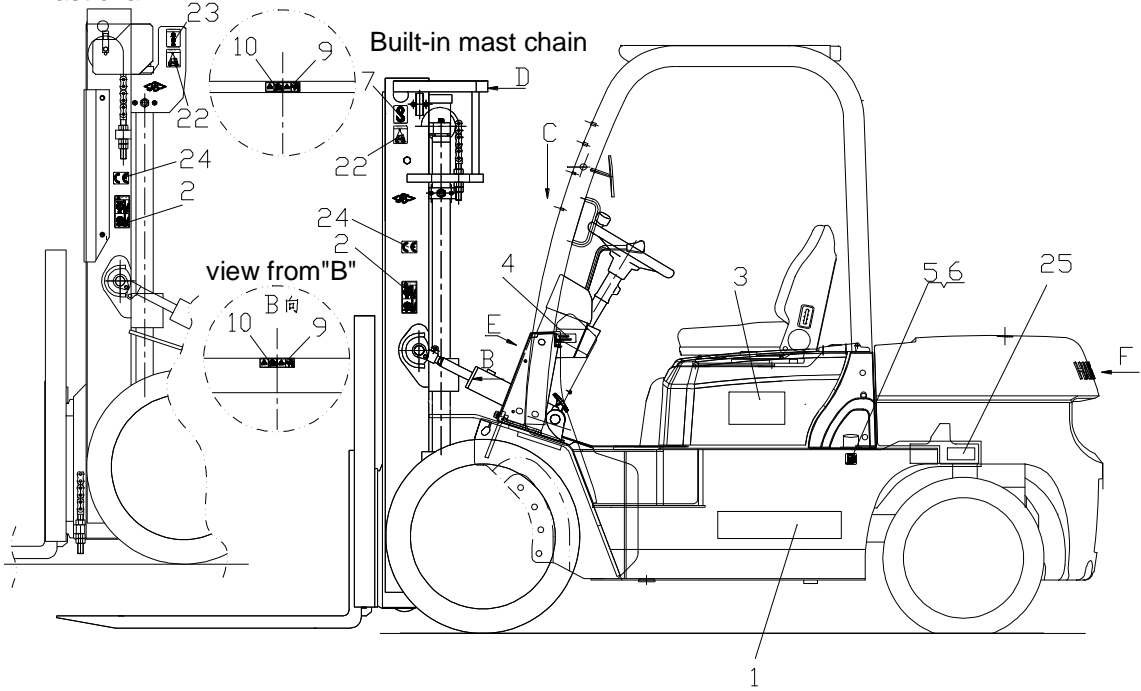

view from "A"

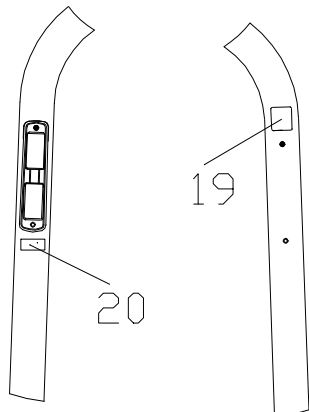

view from "C"

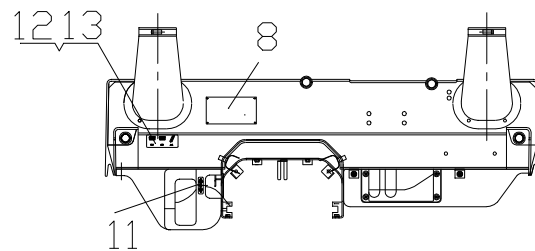

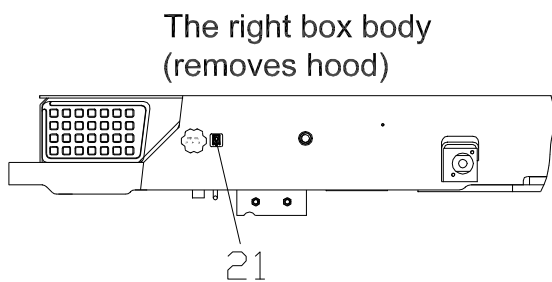
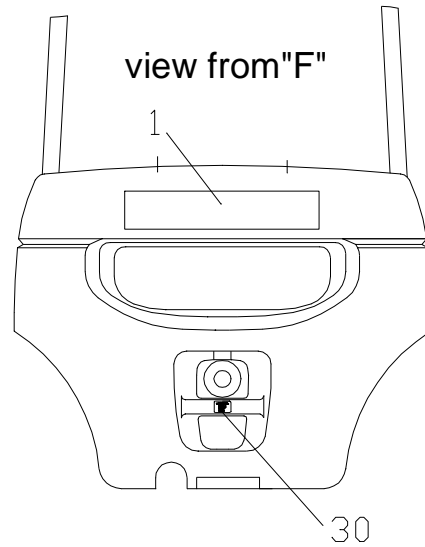
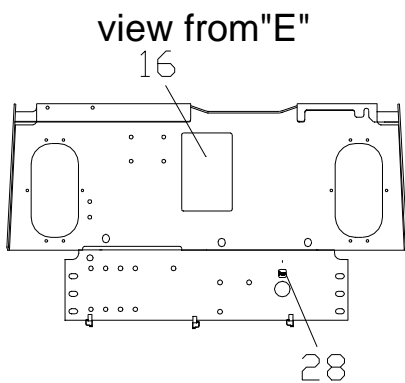
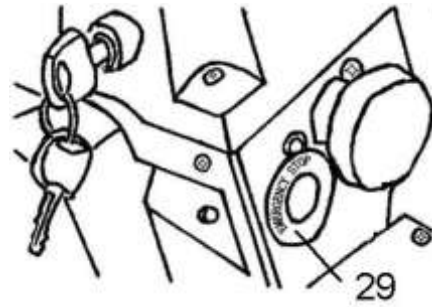
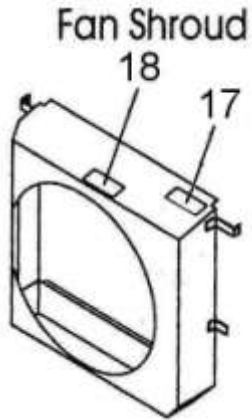

- | | | | |
|---|----------------------|----------------------|----------------------|
| 1. typeface label | 2. danger label | 3. tonnage label | 4. fuse label |
| 5. diesel label | 6. gasoline label | 7. lifting label | 8. product nameplate |
| 9. danger label | 10. danger label | 11. shift label | 12. operate label 1 |
| 13. operate label 2 | 14. load curve label | 15. warning label | |
| 16. lubrication system label | | 17. antifreeze label | |
| 18. fan cut hand & strap nip hand label label | | | 19. noise label |

- 20. prohibit rinse label
- 21.hydraulic oil label
- 22.Lift nameplate
- 23. Lift nameplate
- 24. CE nameplate
- 25.Type pressure label
- 26. Safe belt label
- 27. Brake label
- 28. Speaker label
- 29. Emergency stop label
- 30. Tie down point labe
- 31.LPG label

1、 typeface label

HANGCHA

2、 danger label: adhibit to the outside of mast

No allowed to stand on or under the mast, or it is dangerous to your life.

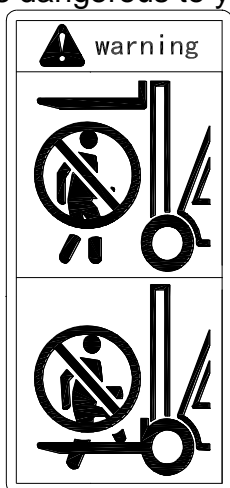

3、 tonnage label

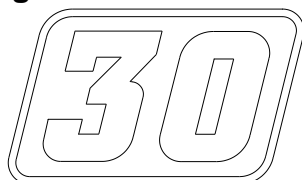

The word “30”means the rated load is 3.0 ton. If the lifting height increases or adds attachment, the rated load will decrease.

4、 fuse label

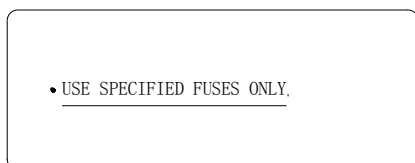

5、 diesel label: show the position for adding oil, at the left rear supporting leg of the cabane. (Not for gasoline and LPG trucks)

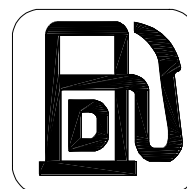

6、 gasoline label: show the position for adding oil, at the left rear supporting leg of the cabane. (Not for gasoline and LPG trucks)



8、 product nameplate

INTERNAL COMBUSTION COUNTERBALANCED FORKLIFT TRUCK			
MODEL . TYPE	I	—	II
SERIES NO.	III	SERVICE WEIGHT	IV kg
NOMINAL LOAD CENTER	VII mm	RATED CAPACITY	V kg
YEAR OF MANUFACTURE	XI		
	MAX .LIFT HEIGHT	LOAD CENTER	CAPACITY AT MAX.L.H
WITHOUT ATTACHMENT	VI mm	VII mm	VIII kg
WITH ATTACHMENT	IX mm	X mm	XI kg
HANGCHA GROUP CO.,LTD.			
License No. : TS2510002-2012 Add: 398 ShiQiao Road, Hangzhou, China			

9、 danger label

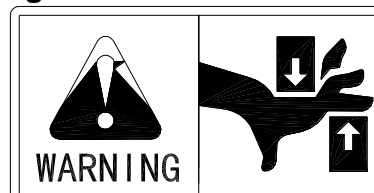

The inner and outer mast, fork frame are all lifting slip parts. The hands are not allowed to reach the place between the inner and outer mast. If the part needs to be check or repaired, the inspection and repair should be

carried out after shutting down the engine. Nobody is allowed on the truck, and the man outside the truck is not allowed to operate the truck, preventing from accident caused by miss operating the mast handle.

10、danger label

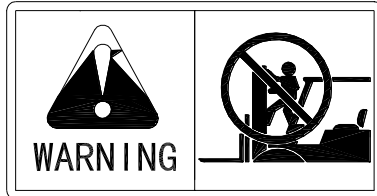

(NO entering label)

Warning: It is dangerous of your life. If the body is clamped among the mast, instrument frame and shield cabane, your life will be dangerous. If the part needs to be check or repaired, the inspection and repair should be carried out after shutting down the engine. Nobody is allowed on the truck, and the man outside the truck is not allowed to operate the truck, preventing from accident caused by miss operating the mast handle.

11、shift label



12、operate labels 1 Machinery truck

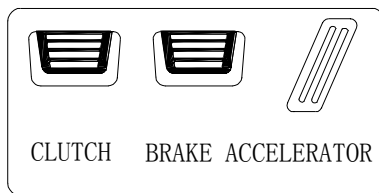

13、operate labels 2 Hydraulic truck

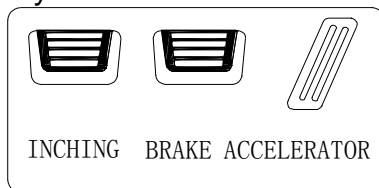

14、load curve label

It shows relation among the position of the load center, max. load and max. lifting height.

If it has side moving and attachment, the load decreases. If the lifting height increases, the load decreases. Before loading, check whether the load and the center distance of load are in the allowed range show in the diagram of load capacity. If the shape of load is complicated, make the most heavy part place in the center of the fork and approach the stop fork frame.

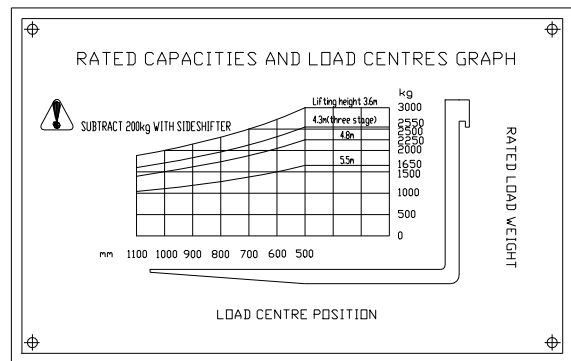

15、warning label

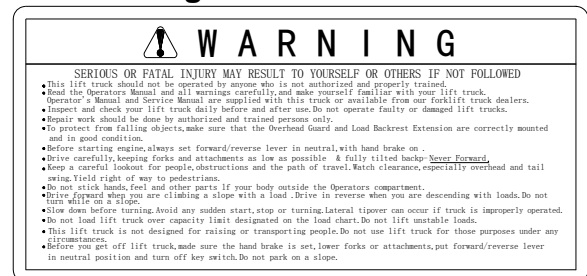

16、lubrication system label

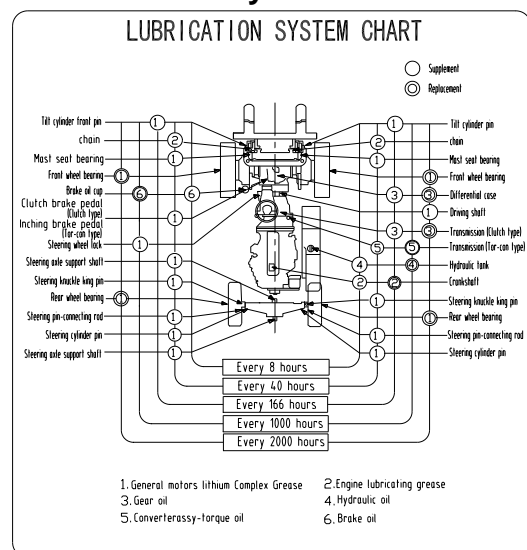

17、antifreeze label



18、Hand cut risk label

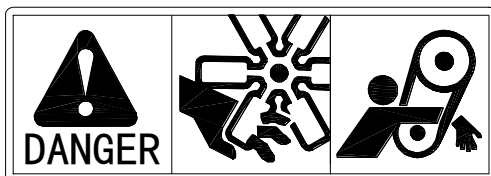

19、noise label

Expect W27
A498BT
engine

A498BT W27
engine

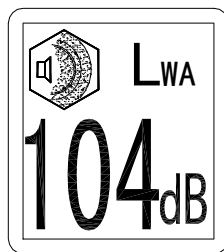
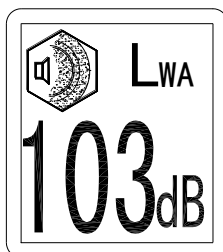

21、hydraulic oil label

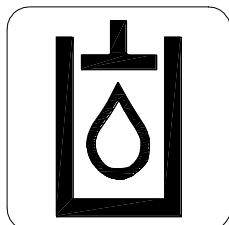

22、hang label: show the hang position. When hanging, the rope should not touch the light and even destroy it.

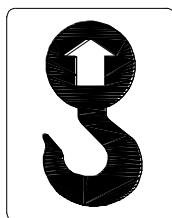

23、hang label: show the hang method. When hanging, the rope should not touch the light and even destroy it.

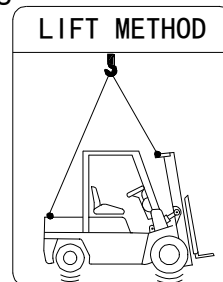

24、CE label



25、Tie down point label

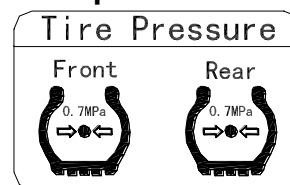

26、Safe belt label

(Defend incline warn label)

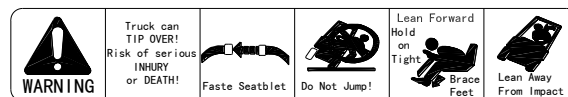

27、Hand brake label

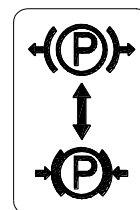

28、Speaker label

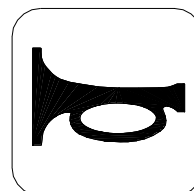

29. Emergency stop label

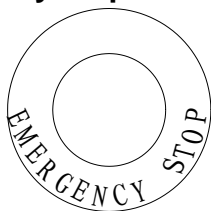

30. Tie down point label

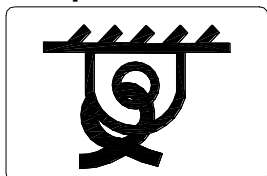

31. LPG label(Only for LPG or double fuel truck)(Only for Europe or option)

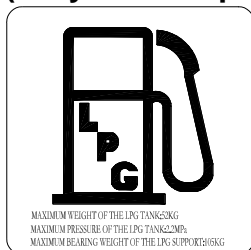

The label on the tank:

LPG tank most weight 52kg

LPG tank most pressure 2.2MPa

Bracket support most weight 105kg

The print position of the series number of truck body

Each truck has a unique truck body series number, its print position is at the Right middle of the forklift truck body.

(On the hydraulic tank)

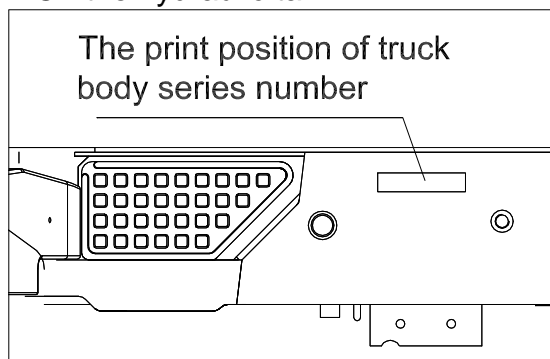

9. Truck's convey, lifting, towing

Hoist the truck

- Use the steel wire ropes to tie the holes in the two side of the outside mast's beam and the hook of the counter balance, then use the lifting device to hoist the truck.

Warning

- When hoist the truck, don't coil the overhead guard with the steel wire.
- The steel wire ropes and the lifting device must be very firm to support the truck because the truck is very heavy.
- Don't lift the truck by hoist the overhead guard.
- When lifting the truck, don't take yourself below the truck.

Convey

- The forklift truck is designed for material handling and short-distance transportation only. It is inappropriate for long-distance transportation. The Fork Lift Truck must be transported by ship, train or lorry, of 5T loading. Tighten the brake lever, take woods to block the front and rear wheels and bind the truck body with enough strong rope, to avoid slippage during transportation.

Towing

- The towing rod on the bottom of the counter balance is used to pull and drag the truck, For installing the rod, first remove the towing rod and then install the ropes. After that, loose the rod.

Note: Loosen the brake lever.

Warning

- Don't tie the steel wire ropes on the unfixed position
- Don't carry a load to steel wire ropes suddenly.

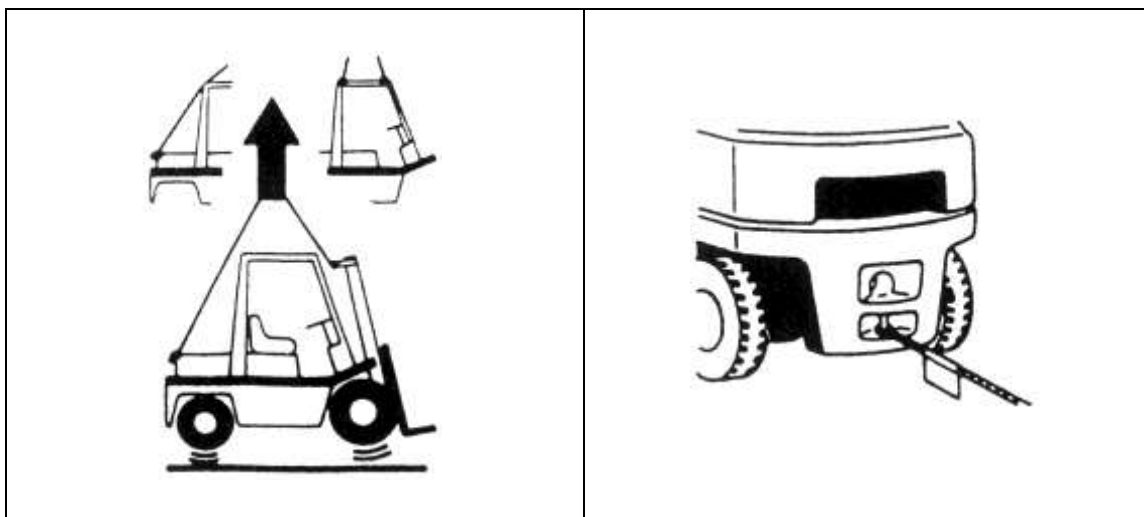

10. Type signification

1t-1.8t

Model	Engine	Main transmission	Rated capacity (t)/ Load center (mm)
CPQ10/15/18N-RW7	Wan feng WF491 Gasoline	JDS18 Machinery transmission gear box	1/500、1.5/500 1.8/500
CPQD10/15/18N-RW7		YQXD18H1 Hydrodynamic power transmission gear box	
CPC10/15/18N-RW9	C240PKJ-20 Diesel (ISUZU)	JDS18HA Machinery transmission gear box	
CPCD10/15/18N-RW9		YQXD18E Hydrodynamic power transmission gear box	
CPC10/15/18N-RW10	ISUZU C240PKJ-30 Diesel	JDS18HA Machinery transmission gear box	
CPCD10/15/18N-RW10		YQXD18E Hydrodynamic power transmission gear box	
CPQ10/15/18N-RW21	K21 Gasoline (NISSAN)	JDS18HA Machinery transmission gear box	
CPQD10/15/18N-RW21		YQXD18HB Hydrodynamic power transmission gear box	
CPCD10/15/18N-RW32	YANMAR 4TNE92 Diesel	YQXD18E Hydrodynamic power transmission gear box	
CPCD10/15/18N-RW32M	4TNE92-HRJ Diesel	Korea hydraulic transmission gearbox	

2t-2.5t

Model	Engine	Main transmission	Rated capacity (t)/ Load center (mm)
CPC20/25N-RW9/W10	C240PKJ-20/ C240PKJ-30 Diesel (ISUZU)	JDS25 Machinery transmission gear box	2/500、2.5/500
CPCD20/25N-RW9/W10		YQXD25 Hydrodynamic power transmission gear box	
CPCD20/25N-RW9B CPCD20/25N-RW10B		OKAMURA Hydrodynamic power transmission gear box	
CPQ20/25N-RW7	Wan Feng BY491 gasoline	JDS25 Machinery transmission gear box	
CPQD20/25N-RW7		YQXD25H1 Hydrodynamic power transmission gear box	
CPCD20/25N-RW27	A498BT1-1 Diesel	YQXD25A Hydrodynamic power transmission gear box	
CPQ20/25N-RW22	K25gasoline (NISSAN)	JDS25 Machinery transmission gear box	
CPQD20/25N-RW22		YQXD25H Hydrodynamic power transmission gear box	
CPQD20/25N-RW22A		NISSAN 2STF150 Hydrodynamic power transmission gear box	
CPQD20/25N-RW22B		OKAMURA Hydrodynamic power transmission gear box	
CPCD20/25N-RW15A	TD27AADiesel (NISSAN)	NISSAN 2STF150 Hydrodynamic power transmission gear box	
CPCD20/25N-RW32	YANMAR 4TNE92 Diesel	YQXD25 Hydrodynamic power transmission gear box	
CPCD20/25N-RW33	4TNE98-BQFLC diesel	YQXD25 Hydrodynamic power transmission gear box	
CPCD20/25N-RW33B		OKAMUR Hydrodynamic power transmission gear box	
CPCD20/25N-RW33M		Korea Hydraulic transmission gear box	
CPQD20/25N-RW26-Y	GM3.0LPG single fuel engine	YQXD25G1 Hydrodynamic power transmission gear box	
CPQD20/25N-RW29-Y	GM3.0 RL LPG single fuel engine	YQXD25G1 Hydrodynamic power transmission gear box	

3t-3.5t

Model	Engine	Main transmission	Rated capacity (t)/ Load center (mm)
CPC30/35N-RW9 CPC30/35N-RW10	C240PKJ-20 / C240PKJ-30 Diesel (ISUZU)	JDS30 Machinery transmission gear box	
CPCD30/35N-RW9 CPCD30/35N-RW10		YQXD30 Hydrodynamic power transmission gear box	
CPCD30/35N-RW9B CPCD30/35N-RW10B		OKAMURA Hydrodynamic power transmission gear box	
CPQ30/35N-RW7	Wan Feng BY491 gasoline	JDS30 Machinery transmission gear box	
CPQD30/355N-RW7		YQXD30H1 Hydrodynamic power transmission gear box	
CPCD30/35N-RW27	A498BT1-1 Diesel	YQXD30A Hydrodynamic power transmission gear box	
CPQ30/35N-RW22	K25gasoline (NISSAN)	JDS30 Machinery transmission gear box	
CPQD30/35N-RW22		YQXD30H Hydrodynamic power transmission gear box	
CPQD30/35N-RW22A		NISSAN 2STF150 Hydrodynamic power transmission gear box	
CPQD30/35N-RW22B		OKAMURA Hydrodynamic power transmission gear box	
CPCD30/35N-RW15A	TD27AA Diesel (NISSAN)	NISSAN 2STF150 Hydrodynamic power transmission gear box	
CPCD30N-RW32	YANMAR 4TNE92 Diesel	YQXD30 Hydrodynamic power transmission gear box	
CPCD30/35N-RW33	4TNE98-BQFLC diesel	YQXD30 Hydrodynamic power transmission gear box	
CPCD30/35N-RW33B		OKAMUR Hydrodynamic power transmission gear box	
CPCD30/35N-RW33M		Korea Hydraulic transmission gear box	
CPQD30/35N-RW26-Y	GM3.0LPG single fuel engine	YQXD30G1Hydrodynamic power transmission gear box	
CPQD30/35N-RW29-Y	GM3.0 RL LPG single fuel engine	YQXD30G1Hydrodynamic power transmission gear box	

11. Performance parameters of R series IC forklift

1t—1.8t R series

Model		CPQD10N-RW7	CPQD15N-RW7	CPQD18N-RW7	
Rated capacity	kg	1000	1500	1750	
Load centre distance	mm	500	500	500	
Overall maximum lift height	mm	3000	3000	3000	
Free lift height	mm	155	155	155	
Maximum lift speed (with load)	mm/s	490	480	540	530
Tilt of the mast	F/B	6°/12°	6°/12°	6°/12°	
Max travel speed (without load)	km/h	15.5	15.5	15.5	
Ground clearance	mm	115	115	115	
Min outside turning radius	mm	1925	1970	2000	
Max negotiable gradient (laden)	%	20	20	20	
Wheel-base	mm	1400	1400	1400	
Track (F/R)	mm	890/897.5	890/897.5	890/897.5	
Service mass	kg	2450	2740	2930	
Overall dimension (L×W×H)mm (include forks)		3145×1080×1995	3185×1080×2110	3222×1080×2110	
Tyre (F/R)		6.5-10-10PR/2 5.00-8-10PR/2	6.5-10-10PR/2 5.00-8-10PR/2	6.5-10-10PR/2 5.00-8-10PR/2	
Battery V/ capacity Ah		12/60	12/60	12/60	
Gasoline engine	Model	BaiYang BY491GP gasoline			
	Rated capacity	41kW/2800r/min			
	Max torque/rpm	161N·m/ 1800~2200 r/min			
	Displacement L	2.237			

Model		CPCD10N-RW10	CPCD15N-RW10	CPCD18N-RW10	
Rated capacity	kg	1000	1500	1750	
Load centre distance	mm	500	500	500	
Overall maximum lift height	mm	3000	3000	3000	
Free lift height	mm	155	155	155	
Maximum lift speed (with load)	mm/s	460	510	510	
Tilt of the mast	F/B	6°/12°	6°/12°	6°/12°	
Max travel speed (without load)	km/h	14.5	14.5	14.5	
Ground clearance	mm	115	115	115	
Min outside turning radius	mm	1925	1970	2005	2000
Max negotiable gradient (laden)	%	20	20	20	
Wheel-base	mm	1400	1400	1400	
Track (F/R)	mm	890/897.5	890/897.5	890/897.5	
Service mass	kg	2450	2740	2930	
Overall dimension (L×W×H)mm (include forks)		3145×1080×2110	3185×1080×2110	3220×1080×2110	
Tyre (F/R)		6.5-10-10PR/2 5.00-8-8PR/2	6.5-10-10PR/2 5.00-8-10PR/2	6.5-10-10PR/2 5.00-8-8PR/2	
Battery V/ capacity Ah		12/60	12/60	12/60	
Diesel engine	Model	ISUZU C240PKJ-30			
	Rated capacity	34.5 kW/2500r/min			
	Max torque/rpm	137.3N·m/1800 r/min			
	Displacement L	2.369			

Model		CPQD10N-RW21	CPQD15N-RW21	CPQD18N-RW21
Rated capacity	kg	1000	1500	1750
Load centre distance	mm	500	500	500
Overall maximum lift height	mm	3000	3000	3000
Free lift height	mm	155	155	155
Maximum lift speed (with load)	mm/s	640	640	640
Tilt of the mast	F/B	6°/12°	6°/12°	6°/12°
Max travel speed (without load)	km/h	15	15	15
Ground clearance	mm	115	115	115
Min outside turning radius	mm	1925	1970	2000
Max negotiable gradient (laden)	%	20	20	20
Wheel-base	mm	1400	1400	1400
Track (F/R)	mm	890/897.5	890/897.5	890/897.5
Service mass	kg	2420	2690	2880
Overall dimension (L×W×H)mm (include forks)		3145×1080×2110	3185×1080×2110	3220×1080×2110
Tyre (F/R)		6.5-10-10PR/2 5.00-8-10PR/2	6.5-10-10PR/2 5.00-8-10PR/2	6.5-10-10PR/2 5.00-8-10PR/2
Battery V/ capacity Ah		12/60	12/60	12/60
Diesel engine	Model	NISSAN K21		
	Rated capacity	31.2 kw/2250 r/min		
	Max torque/rpm	143.7N • m/1600 r/min		
	Displacement L	1.982		

Model		CPCD10N-RW32	CPCD15N-RW32	CPCD18N-RW32
Rated capacity	kg	1000	1500	1750
Load centre distance	mm	500	500	500
Overall maximum lift height	mm	3000	3000	3000
Free lift height	mm	155	155	155
Maximum lift speed (with load)	mm/s	560	560	560
Tilt of the mast	F/B	6°/12°	6°/12°	6°/12°
Max travel speed (without load)	km/h	15	15	15
Ground clearance	mm	115	115	115
Min outside turning radius	mm	1970	1970	1970
Max negotiable gradient (laden)	%	20	20	20
Wheel-base	mm	1400	1400	1400
Track (F/R)	mm	890/897.5	890/897.5	890/897.5
Service mass	kg	2500	2740	2930
Overall dimension (L×W×H)mm (include forks)		3145×1080×1995	3185×1080×2110	3222×1080×2110
Tyre (F/R)		6.5-10-10PR/2 5.00-8-8PR/2	6.5-10-10PR/2 5.00-8-8PR/2	6.5-10-10PR/2 5.00-8-8PR/2
Battery V/ capacity Ah		12/60	12/60	12/60
Diesel engine	Model	YANMAR 4TNE92-HRJ Diesel		
	Rated capacity	32.8kW/2450r/min		
	Max torque/rpm	149.4N·m/ 1600 r/min		
	Displacement L	2.659		

2t-3.5t R series

Model		CPQ20N-RW7 CPQD20N-RW7	CPQ25N-RW7 CPQD25N-RW7	CPQ30N-RW7 CPQD30N-RW7	CPQ35N-RW7 CPQD35N-RW7
Rated capacity	kg	2000	2500	3000	3500
Load centre distance	mm	500	500	500	500
Overall maximum lift height	mm	3000	3000	3000	3000
Free lift height	mm	140	140	155	155
Maximum lift speed (with load)	mm/s	500	450	430	350
Tilt of the mast	F/B	6°/12°	6°/12°	6°/12°	6°/12°
Max travel speed (without load)	km/h	22.5	22.5	21	21
Ground clearance	mm	105	105	130	130
Min outside turning radius	mm	2260	2320	2480	2520
Max negotiable gradient (laden)	%	20	20	20	20
Wheel-base	mm	1650	1650	1760	1760
Track (F/R)	mm	965/970.5	965/970.5	1005/973.5	1005/973.5
Service mass	kg	3600	3675	4255	4555
Overall dimension (L×W×H)mm (include forks)		3600×1155×2120	3675×1155×2120	3820×1225×2150	3870×1225×2150
Tyre (F/R)		7.00-12-12PR/2 6.00-9-10PR/2	7.00-12-12PR/2 6.00-9-10PR/2	28×9-15-12PR/2 6.50-10-10PR/2	28×9-15-12PR/2 6.50-10-10PR/2
Battery V/ capacity Ah		12/60	12/60	12/90	12/90
Gasoline engine	Model	BaiYang BY491GP gasoline			
	Rated capacity	41kW/2800r/min			
	Max torque/rpm	161N·m/ 1800~2200 r/min			
	Displacement L	2.237			

Model		CPC20N-RW10 CPCD20N-RW10	CPC25N-RW10 CPCD25N-RW10	CPC30N-RW10 CPCD30N-RW10
Rated capacity	kg	2000	2500	3000
Load centre distance	mm	500	500	500
Overall maximum lift height	mm	3000	3000	3000
Free lift height	mm	140	140	145
Maximum lift speed (with load)	mm/s	430	480	380
Tilt of the mast	F/B	6°/12°	6°/12°	6°/12°
Max travel speed (without load) km/h	mechanical	1 shift	9	8
		2 shift	20.5	19
	hydraulic	20.5	19	
Ground clearance	mm	105	105	130
Min outside turning radius	mm	2260	2320	2480
Max negotiable gradient (laden)	%	20	18	18
Wheel-base	mm	1650	1650	1760
Track (F/R)	mm	965/970.5	965/970.5	1005/973.5
Service mass	kg	3440	3765	4255
Overall dimension (L×W×H)mm (include forks)		3600×1155×2120	3675×1155×2120	3820×1225×2150
Tyre (F/R)		7.00-12-12PR/2 6.00-9-10PR/2	7.00-12-12PR/2 6.00-9-10PR/2	28×9-15-12PR/2 6.50-10-10PR/2
Battery V/ capacity Ah		12/90	12/90	12/90
Diesel engine	Model	ISUZU C240PKJ-30		
	Rated capacity	34.5 kW/2500r/min		
	Max torque/rpm	137.3N·m/1800 r/min		
	Displacement L	2.369		

Model		CPCD20N-R10B	CPCD25N- RW10B	CPCD30N- RW10B	CPCD35N-RW10B
Rated capacity	kg	2000	2500	3000	3500
Load centre distance	mm	500	500	500	500
Overall maximum lift height	mm	3000	3000	3000	3000
Free lift height	mm	150	150	155	155
Maximum lift speed (with load)	mm/s	410	540	380	340
Tilt of the mast	F/B	6°/12°	6°/12°	6°/12°	6°/12°
Max travel speed (without load)	km/h	20. 5	20. 5	19	19.5
Ground clearance	mm	105	105	130	130
Min outside turning radius	mm	2260	2320	2480	2415
Max negotiable gradient (laden)	%	20	18	18	15
Wheel-base	mm	1665	1665	1760	1760
Track (F/R)	mm	965/970.5	965/970.5	1005/973.5	1005/973.5
Service mass	kg	3440	3765	4255	4555
Overall dimension (L×W×H)mm (include forks)		3615×1155×2120	3690×1155×2120	3820×1225×2150	3870×1225×2160
Tyre (F/R)		7.00-12-12PR/2 6.00-9-10PR/2	7.00-12-12PR/2 6.00-9-10PR/2	28×9-15-12PR/2 6.50-10-10PR/2	28×9-15-12PR/2 6.50-10-10PR/2
Battery V/ capacity Ah		12/90	12/90	12/90	12/90
Diesel engine	Model	ISUZU C240PKJ-30			
	Rated capacity	34.5 kW/2500r/min			
	Max torque/rpm	137.7N·m/1800 r/min			
	Displacement L	2.369			
Transmission F/R		OKAMURA 1/1			

Model		CPCD20N-RW15A	CPCD25N-RW15A	CPCD30N-RW15A	CPCD35N-RW15A
Rated capacity	kg	2000	2500	3000	3500
Load centre distance	mm	500	500	500	500
Overall maximum lift height	mm	3000	3000	3000	3000
Free lift height	mm	150	150	155	155
Maximum lift speed (with load)	mm/s	500	500	460	360
Tilt of the mast	F/B	6°/12°	6°/12°	6°/12°	6°/12°
Max travel speed (without load)	km/h	18	18	18	18
Ground clearance	mm	105	105	130	130
Min outside turning radius	mm	2175	2235	2375	2415
Max negotiable gradient (laden)	%	25	25	25	25
Wheel-base	mm	1650	1650	1760	1760
Track (F/R)	mm	965/970	965/970	1005/975	1005/975
Service mass	kg	3440	3765	4255	4555
Overall dimension (L×W×H)mm (include forks)		3600×1150×2120	3675×1150×2120	3820×1225×2150	3870×1225×2150
Tyre (F/R)		7.00-12-12PR 6.00-9-10PR	7.00-12-12PR 6.00-9-10PR	28×9-15-12PR/2 6.50-10-10PR/2	28×9-15-12PR/2 6.50-10-10PR/2
Battery V/ capacity Ah		12/90/20h	12/90/20h	12/90/20h	12/90/20h
Diesel engine	Model	TD27AA			
	Rated capacity	38.5 kw/2500r/min			
	Max torque/rpm	160N • m/2300 r/min			
	Displacement L	2.663			
Transmission F/R		NISSAN 1/1			

Model		CPQ20N-RW22 CPQD20N-RW22	CPQ25N-RW22 CPQD25N-RW22	CPQ30N-RW22 CPQD30N-RW22	CPQ35N-RW22 CPQD35N-RW22	
Rated capacity	kg	2000	2500	3000	3500	
Load centre distance	mm	500	500	500	500	
Overall maximum lift height	mm	3000	3000	3000	3000	
Free lift height	mm	140	150 140	155	140	
Maximum lift speed (with load)	mm/s	500 560	570 560	500	560	
Tilt of the mast	F/B	6°/12°	6°/12°	6°/12°	6°/12°	
Max travel speed (without load) km/h	mechanical	1 shift	9	9	8	8
		2 shift	23	23	21.5	21.5
	hydraulic	22	21.5	19.5	19.5	
Ground clearance	mm	105	105	130	130	
Min outside turning radius	mm	2260	2320	2480	2520	
Max negotiable gradient (laden)	%	20	20	20	20	
Wheel-base	mm	1650	1665	1760	1760	
Track (F/R)	mm	965/970	965/970	1005/975	1005/975	
Service mass	kg	3440	3765	4255	4555	
Overall dimension (L×W×H)mm (include forks)		3600×1155×2120	3675×1155×2120	3820×1225×2150	3870×1225×2150	
Tyre (F/R)		7.00-12-12PR 6.00-9-10PR	7.00-12-12PR 6.00-9-10PR	28×9-15-12PR/2 6.50-10-10PR/2	28×9-15-12PR/2 6.50-10-10PR/2	
Battery V/ capacity Ah		12/60	12/60	12/60	12/60	
Gasoline engine	Model	K25				
	Rated capacity	37.4 kW/2300r/min				
	Max torque/rpm	176.5N·m/1600 r/min				
	Displacement L	2.472				

Model		CPQ20N-RW22 CPQD20N-RW22	CPQ25N-RW22 CPQD25N-RW22	CPQ30N-RW22 CPQD30N-RW22	CPQ35N-RW22 CPQD35N-RW22	
Rated capacity	kg	2000	2500	3000	3500	
Load centre distance	mm	500	500	500	500	
Overall maximum lift height	mm	3000	3000	3000	3000	
Free lift height	mm	140	150 140	155	140	
Maximum lift speed (with load)	mm/s	500 560	570 560	500	560	
Tilt of the mast	F/B	6°/12°	6°/12°	6°/12°	6°/12°	
Max travel speed (without load) km/h	mechanical	1 shift	9	9	8	8
		2 shift	23	23	21.5	21.5
	hydraulic	22	21.5	19.5	19.5	
Ground clearance	mm	105	105	130	130	
Min outside turning radius	mm	2260	2320	2480	2520	
Max negotiable gradient (laden)	%	20	20	20	20	
Wheel-base	mm	1650	1665	1760	1760	
Track (F/R)	mm	965/970	965/970	1005/975	1005/975	
Service mass	kg	3440	3765	4255	4555	
Overall dimension (L×W×H)mm (include forks)		3600×1155×2120	3675×1155×2120	3820×1225×2150	3870×1225×2150	
Tyre (F/R)		7.00-12-12PR 6.00-9-10PR	7.00-12-12PR 6.00-9-10PR	28×9-15-12PR/2 6.50-10-10PR/2	28×9-15-12PR/2 6.50-10-10PR/2	
Battery V/ capacity Ah		12/60	12/60	12/60	12/60	
Gasoline engine	Model	K25				
	Rated capacity	37.4 kW/2300r/min				
	Max torque/rpm	176.5N·m/1600 r/min				
	Displacement L	2.472				

Model		CPQD20N-RW22A	CPQD25N-RW22A	CPQD30N-RW22A	CPQD35N-RW22A
Rated capacity	kg	2000	2500	3000	3500
Load centre distance	mm	500	500	500	500
Overall maximum lift height	mm	3000	3000	3000	3000
Free lift height	mm	150	150	155	155
Maximum lift speed (with load)	mm/s	560	560	450	350
Tilt of the mast	F/B	6°/12°	6°/12°	6°/12°	6°/12°
Max travel speed (without load)	km/h	19.5	19.5	19.5	19.5
Ground clearance	mm	105	105	130	130
Min outside turning radius	mm	2260	2260	2480	2480
Max negotiable gradient (laden)	%	20	20	20	15
Wheel-base	mm	1665	1665	1760	1760
Track (F/R)	mm	965/970.5	965/970.5	1005/973.5	1005/973.5
Service mass	kg	3440	3765	4255	4555
Overall dimension (L×W×H)mm (include forks)		3600×1155×2120	3600×1155×2120	3870×1225×2150	3870×1225×2150
Tyre (F/R)		7.00-12-12PR/2 6.00-9-10PR/2	7.00-12-12PR/2 6.00-9-10PR/2	28×9-15-12PR/2 6.50-10-10PR/2	28×9-15-12PR/2 6.50-10-10PR/2
Battery V/ capacity Ah		12/60	12/60	12/60	12/60
Gasoline engine	Model	K25			
	Rated capacity	37.4 kW/2300r/min			
	Max torque/rpm	176.5N·m/1600 r/min			
	Displacement L	2.472			

Model		CPQD20N-RW22B	CPQD25N-RW22B	CPQD30N-RW22B	CPQD35N-RW22B
Rated capacity	kg	2000	2500	3000	3500
Load centre distance	mm	500	500	500	500
Overall maximum lift height	mm	3000	3000	3000	3000
Free lift height	mm	150	150	155	155
Maximum lift speed (with load)	mm/s	560	560	450	350
Tilt of the mast	F/B	6°/12°	6°/12°	6°/12°	6°/12°
Max travel speed (without load)	km/h	21	21	20	20
Ground clearance	mm	105	105	130	130
Min outside turning radius	mm	2260	2320	2480	2520
Max negotiable gradient (laden)	%	20	20	20	20
Wheel-base	mm	1665	1665	1760	1760
Track (F/R)	mm	965/970.5	965/970.5	1005/973.5	1005/973.5
Service mass	kg	3440	3765	4255	4555
Overall dimension (L×W×H)mm (include forks)		3615×1155×2120	3690×1155×2120	3820×1225×2150	3870×1225×2150
Tyre (F/R)		7.00-12-12PR 6.00-9-10PR	7.00-12-12PR 6.00-9-10PR	28×9-15-12PR/2 6.50-10-10PR/2	28×9-15-12PR/2 6.50-10-10PR/2
Battery V/ capacity Ah		12/60	12/60	12/60	12/60
Gasoline engine	Model	K25			
	Rated capacity	37.4 kW//2300r/min			
	Max torque/rpm	176.5N·m/1600 r/min			
	Displacement L	2472			

Model		CPCD20N-RW27	CPCD25N-RW27	CPCD30N-RW27	CPCD35N-RW27
Rated capacity	kg	2000	2500	3000	3500
Load centre distance	mm	500	500	500	500
Overall maximum lift height	mm	3000	3000	3000	3000
Free lift height	mm	140	140	145	145
Maximum lift speed (with load)	mm/s	470	540	430	340
Tilt of the mast	F/B	6°/12°	6°/12°	6°/12°	6°/12°
Max travel speed (without load)	km/h	20.5	20.5	19	19
Ground clearance	mm	105	105	130	130
Min outside turning radius	mm	2260	2320	2480	2520
Max negotiable gradient (laden)	%	20	20	15	15
Wheel-base	mm	1650	1650	1760	
Track (F/R)	mm	965/970.5	965/970.5	1005/973.5	
Service mass	kg	3440	3440	4255	4555
Overall dimension (L×W×H)mm (include forks)		3600×1155×2120	3675×1155×2120	3820×1225×2150	3870×1225×2150
Tyre (F/R)		7.00-12-12PR/2 6.00-9-10PR/2	7.00-12-12PR/2 6.00-9-10PR/2	28×9-15-12PR/2 6.50-10-10PR/2	28×9-15-12PR/2 6.50-10-10PR/2
Battery V/ capacity Ah		12/90	12/90	12/90	12/90
Diesel engine	Model	A498BT1			
	Rated capacity	36.8 kW/2400r/min			
	Max torque/rpm	193N·m/ 1800 r/min			
	Displacement L	3.168			

Model		CPCD20N-RW32	CPCD25N-RW32	CPCD30N-RW32
Rated capacity	kg	2000	2500	3000
Load centre distance	mm	500	500	500
Overall maximum lift height	mm	3000	3000	3000
Free lift height	mm	150	150	155
Maximum lift speed (with load)	mm/s	535	535	430
Tilt of the mast	F/B	6°/12°	6°/12°	6°/12°
Max travel speed (without load)	km/h	20	20	18
Ground clearance	mm	105	105	130
Min outside turning radius	mm	2260	2320	2480
Max negotiable gradient (laden)	%	20	20	15
Wheel-base	mm	1650	1650	1760
Track (F/R)	mm	965/970.5	965/970.5	1005/973.5
Service mass	kg	3440	3765	4280
Overall dimension (L×W×H)mm (exclusive forks)		3600×1155×1985	3675×1155×1985	3820×1225×2150
Tyre (F/R)		7.00-12-12PR/2 6.00-9-10PR/2	7.00-12-12PR/2 6.00-9-10PR/2	28×9-15-12PR/2 6.50-10-10PR/2
Battery V/ capacity Ah		12/90	12/90	12/90
Diesel engine	Model	YANMAR 4TNE92-HRJ		
	Rated capacity	32.8 kW/2450r/min		
	Max torque/rpm	149.4N-m/ 1600 r/min		
	Displacement L	2.659		

Model		CPCD20N-RW33 CPCD20N-RW33B	CPCD25N-RW33 CPCD25N-RW33B	CPCD30N-RW33 CPCD30N-RW33B	CPCD35N-RW33 CPCD35N-RW33B
Rated capacity	kg	2000	2500	3000	3500
Load centre distance	mm	500	500	500	500
Overall maximum lift height	mm	3000	3000	3000	3000
Free lift height	mm	150	150	155	155
Maximum lift speed (with load)	mm/s	580	580	460	360
Tilt of the mast	F/B	6°/12°	6°/12°	6°/12°	6°/12°
Max travel speed (without load)	km/h	20	20	18 20	18.5 20
Ground clearance	mm	105	105	130	130
Min outside turning radius	mm	2260	2320	2480	2520
Max negotiable gradient (laden)	%	20	20	20	20
Wheel-base	mm	1650	1650	1760	1760
Track (F/R)	mm	965/970.5	965/970.5	1005/973.5	1005/973.5
Service mass	kg	3440	3765	4280	4555
Overall dimension (L×W×H)mm (include forks)		3600×1155×2120	3675×1155×2120	3820×1225×2150	3820×1225×2150
Tyre (F/R)		7.00-12-12PR/2 6.00-9-10PR/2	7.00-12-12PR/2 6.00-9-10PR/2	28×9-15-12PR/2 6.50-10-10PR/2	28×9-15-12PR/2 6.50-10-10PR/2
Battery V/ capacity Ah		12/90	12/90	12/90	12/90
Diesel engine	Model	YANMAR 4TNE98-BQFLC			
	Rated capacity	44.3 kW/2300r/min			
	Max torque/rpm	206N·m/ 1700 r/min			
	Displacement L	3.319			

Model		CPCD20N-RW33M	CPCD25N-RW33M	CPCD30N-RW33M	CPCD35N-RW33M
Rated capacity	kg	2000	2500	3000	3500
Load centre distance	mm	500	500	500	500
Overall maximum lift height	mm	3000	3000	3000	3000
Free lift height	mm	150	150	155	155
Maximum lift speed (with load)	mm/s	500	500	470	370
Tilt of the mast	F/B	6°/12°	6°/12°	6°/12°	6°/12°
Max travel speed (without load)	km/h	19	19	20	20
Ground clearance	mm	105	105	130	130
Min outside turning radius	mm	2175	2235	2375	2415
Max negotiable gradient (laden)	%	20	20	20	20
Wheel-base	mm	1665	1665	1760	1760
Track (F/R)	mm	965/970.5	965/970.5	1005/973.5	1005/973.5
Service mass	kg	3440	3765	4280	4555
Overall dimension (L×W×H)mm (include forks)		3615×1155×2120	3690×1155×2120	3820×1225×2150	3870×1225×2150
Tyre (F/R)		7.00-12-12PR/2 6.00-9-10PR/2	7.00-12-12PR/2 6.00-9-10PR/2	28×9-15-12PR/2 6.50-10-10PR/2	28×9-15-12PR/2 6.50-10-10PR/2
Battery V/ capacity Ah		12/100	12/100	12/90	12/100
Diesel engine	Model	YANMAR 4TNE98-BQFLC			
	Rated capacity	44.3 kW/2300r/min			
	Max torque/rpm	206N·m/ 1700 r/min			
	Displacement L	3.319			

Model		CPCD20N-RW26-Y	CPCD25N-RW26-Y	CPCD30N-RW26-Y	CPCD35N-RW26-Y
Rated capacity	kg	2000	2500	3000	3500
Load centre distance	mm	500	500	500	500
Overall maximum lift height	mm	3000	3000	3000	3000
Free lift height	mm	150	150	155	155
Maximum lift speed (with load)	mm/s	540	540	430	340
Tilt of the mast	F/B	6°/12°	6°/12°	6°/12°	6°/12°
Max travel speed (without load)	km/h	20	20	18.5	18.5
Ground clearance	mm	105	105	130	130
Min outside turning radius	mm	2260	2320	2480	2520
Max negotiable gradient (laden)	%	20	20	20	20
Wheel-base	mm	1650	1650	1760	1760
Track (F/R)	mm	965/970.5	965/970.5	1005/973.5	1005/973.5
Service mass	kg	3440	3765	4280	4555
Overall dimension (L×W×H)mm (include forks)		3600×1155×2120	3675×1155×2120	3820×1225×2150	3870×1225×2145
Tyre (F/R)		7.00-12-12PR/2 6.00-9-10PR/2	7.00-12-12PR/2 6.00-9-10PR/2	28×9-15-12PR/2 6.50-10-10PR/2	28×9-15-12PR/2 6.50-10-10PR/2
Battery V/ capacity Ah		12/60	12/60	12/60	12/60
LPG engine	Model	IMPCO GM3.0L (LPGSingle-fuel)			
	Rated capacity	50 kw/2500r/min			
	Max torque/rpm	189N·m/1600 r/min			

Model		CPCD20N-RW29-Y	CPCD25N-RW29-Y	CPCD30N-RW29-Y	CPCD35N-RW29-Y
Rated capacity	kg	2000	2500	3000	3500
Load centre distance	mm	500	500	500	500
Overall maximum lift height	mm	3000	3000	3000	3000
Free lift height	mm	150	150	155	155
Maximum lift speed (with load)	mm/s	540	540	430	340
Tilt of the mast	F/B	6°/12°	6°/12°	6°/12°	6°/12°
Max travel speed (without load)	km/h	20	20	18.5	18.5
Ground clearance	mm	105	105	130	130
Min outside turning radius	mm	2260	2320	2480	2520
Max negotiable gradient (laden)	%	20	20	20	20
Wheel-base	mm	1650	1650	1760	1760
Track (F/R)	mm	965/970.5	965/970.5	1005/973.5	1005/973.5
Service mass	kg	3440	3765	4280	4555
Overall dimension (L×W×H)mm (include forks)		3600×1155×2120	3675×1155×2120	3820×1225×2150	3870×1225×2145
Tyre (F/R)		7.00-12-12PR/2 6.00-9-10PR/2	7.00-12-12PR/2 6.00-9-10PR/2	28×9-15-12PR/2 6.50-10-10PR/2	28×9-15-12PR/2 6.50-10-10PR/2
Battery V/ capacity Ah		12/60	12/60	12/60	12/60
LPG engine	Model	PSI GM3.0L RL (LPGSingle-fuel)			
	Rated capacity	47 kw/2500r/min			
	Max torque/rpm	200N·m/1600 r/min			

12. Operation, disassembly and installation of cab



2 fastening bolt,
inside rubber plug

2 fastening bolt, outside

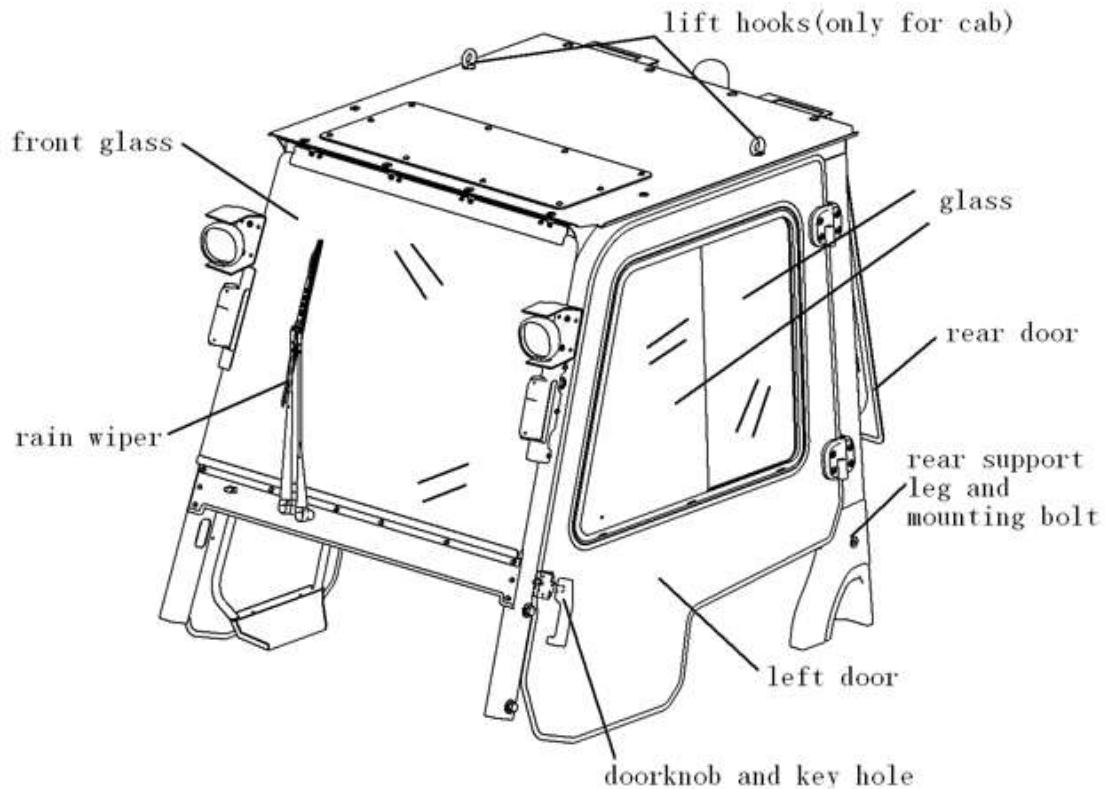

The operation of cab:

1. Open left door with key, enter into cab.
2. Close door, make sure left and right door close before working.
3. The glass of left and right door can be moved by draw button on the glass.
4. The rear door can be opened by loosening lock buckle.

Disassembling cab:

1. Stop the truck on solid and smooth level ground; close switch, pull down hand brake.
2. Remove 4 bolts from left front and right front legs. To high position exhaust, the fastening bolts should be removed.
3. Pull out 4 rubber plugs from left rear and right rear legs, remove 4 bolts from left rear and right rear legs.
4. Lift cab a little with crane.
5. Remove switch connection of fan, rain wiper, alarm light etc., remove wire from 4 support legs, and slip into support legs.
6. Put down cab slowly and lightly, avoid pressing wire and keep wire intact.

Installing cab:

The installing procedure is opposite to removing procedure. But remove the bolts which connect head frame and support legs, after fastening support legs and truck body, then fastening connected bolts connected head frame and support legs, fastening torque of bolts connected support legs and truck body: $T=137\text{N}\cdot\text{m} \sim 167\text{N}\cdot\text{m}$. bolts for connecting head frame and support legs: $T=110\text{N}\cdot\text{m} \sim 140\text{N}\cdot\text{m}$

13. Operation and notice about LPG forklift

More details refer to 《operation and maintenance manual and service Manual of 1.5t-3.5t R series LPG forklift (American impco combustion system)(Italy BRC combustion system)》 .

LPG fuel system consists of LPG cylinder, petrol solenoid valve, LPG solenoid valve with filter, LPG vaporizer, adapter, LPG-petrol select switch and level indication. LPG comes from the LPG cylinder, passing through the combination valve, the high-pressured pipe, the filter, and the solenoid valve in sequence, enters the LPG vaporizer to vaporize, then mix with air in certain proportion in the adapter, and combust in the engine cylinder to drive the forklift truck to work.

There is double fuel switch at the top surface of instruments panel

(1) the operation of double fuel switch

- ① Turn switch to LPG, then fuel is becoming LPG;
- ② Turn switch to GAS, then fuel is becoming gasoline.
- ③ Neutral position, LPG and gasoline are both stopped.

(2) Starting up the engine

1. By gasoline

Shut off LPG, switch on the petrol switch for several seconds, after petrol is flowing into the floater room of the carburetor, turn the ignition key to start the motor-----the engine is started by petrol;

2. By LPG

a. Starting up when there is no petrol in the carburetor: if there is no petrol in the carburetor before starting-up, you could start up the engine directly by LPG, that is, to shut off the petrol switch, but switch on the LPG switch for several seconds, turn the ignition key to start the motor-----the engine is started by LPG;

b. Starting up when there is petrol in the carburetor: it is some difficult to start up when there is petrol in the carburetor, you should switch the select switch to the neutral position, start up the engine by petrol. When petrol in the carburetor is about to be used up and the engine is running slower, switch on the LPG switch to fuel by LPG. Or after petrol in the carburetor is used up and the engine is halted, switch on the LPG switch, turn the ignition key to start the motor-----the engine is started.

(3) Change fuel during the engine runs

1. Change from LPG to petrol:

Directly switch the select switch from the LPG position to GAS position, the engine fuel is changed from LPG to petrol.

2. Change from petrol to LPG:

Shut off the petrol switch, When petrol in the carburetor is about to be used up, the engine runs slower, switch on the LPG switch rapidly to fuel by LPG.

Outpouring limit valve

Once the outpouring limit valve is opened (see FIG A), LPG is flowing to the LPG solenoid valve through the outlet When outpouring exceeds the stated value, or the pipe is broken, the outpouring device on the valve will be closed automatically. If leaving the forklift unused for a long term, you should close the limit-outpouring valve.

Adapter

The adapter is to mix the vaporized LPG with air and to send them into the engine to meet kinds of working conditions according to the engine.

LPG cylinder

1. function

It composed of safety valve, LPG inlet, quick fitting and other relevant accessories. It supports and stores fuel, and it is fixed at the back of truck. The functions:

a. shut off valve

It control inlet and outlet line of the LPG.

b. Charging limit valve

open the charging limit valve to charge LPG till the charging device is automatically closed when 70%- 80% volume of the container is full.

c. Level indication

The digital shows percentage of the remainder volume.

d. Outpouring limit valve

When outpouring exceeds the stated value, or the pipe is broken, the outpouring device on the valve will be closed automatically.

e. Safety valve

Safety valve will open automatically when pressure in cylinder is over the standard pressure.

2. Main parameters

Work temperature: $-40^{\circ}\text{C} \sim +60^{\circ}\text{C}$; Work pressure : 2.2MPa; opening pressure of safety valve: $2.5 \text{ MPa} \pm 0.2 \text{ MPa}$; Max. capacity : 80% of cylinder volume。

3. Cylinder structure



1. Charge valve (inlet port and dustproof cover)

2. Installing mark

4. Fixed pin

6. Level indication

3. Outlet valve (outlet connector)

5. Outlet shut off valve

7. Inlet shut off valve

4. Cylinder replacement

Paste safety operation procedures on cylinder



- (1) make the truck stay on flat and stability ground, stop engine, pull hand brake;
- (2) remove cylinder:
 - a. Close outlet shut off valve, and remove outlet connector.



- b. Loosen cylinder fixed parts, see followed Fig:

Metal band bracket

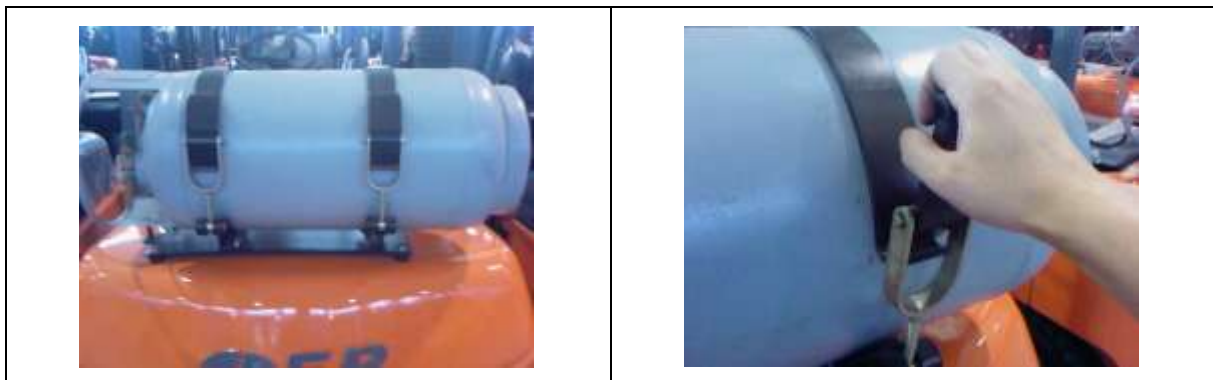

buckle belt bracket



Buckle belt and tighten device



1. Right hand hold tighten device, use forefinger, middle finger, and ring finger to pull lock buckle out.



2. Keep 1 procedure, and push up tighten device till touch cylinder.



3. Keep the lock buckle out and pull downward the whole tighten device.



4. Then buckle belt is loosened from tighten device

5. Remove the left tighten device from buckle belt by the same way.

Remove cylinder and charge

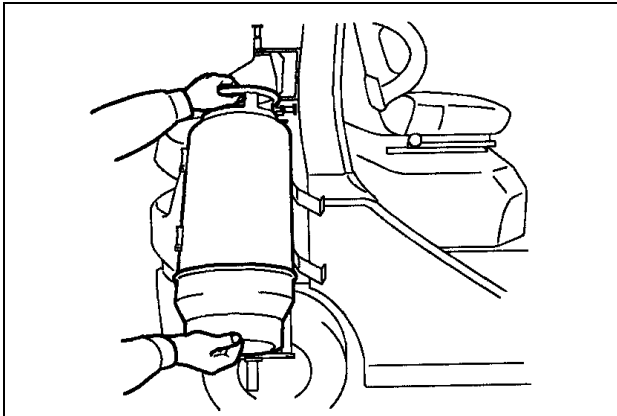

Notice :

1. Please avoiding cylinder hit counterpoise when taking it down form truck.
2. Make sure the outlet shut off valve closed.
3. When charging the place must have charging license which is awarded by Quality and Technical Supervision Bureau . It is forbidden to charge by self and the component must accord with table 1.

Notice : a) 1# may use more than -20°C ;
b) 2 # may use more than -10°C ;
c) 3 # may use more than 0°C .

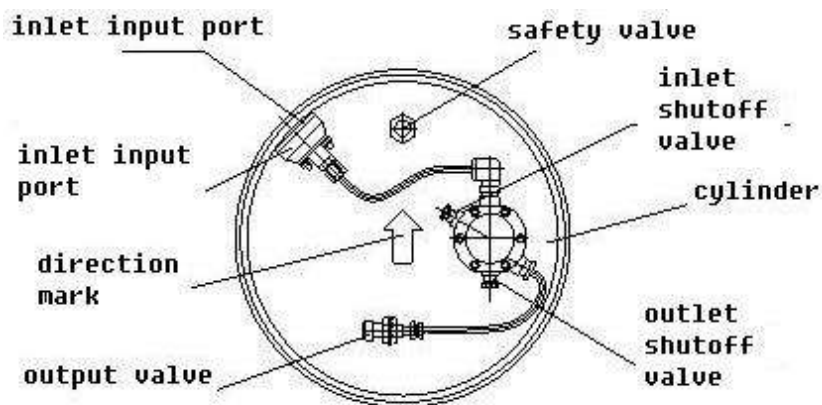

Table 1 technique parameter of LPG special for vehicle

Item component com position		Quality parameter			Trial
		1#	2#	3#	
37.8 ⁰ C vapour (indication) k Pa		≤1430	890~1430	660~1340	GB/T 6602 ^a
Component %	propane	>85	>65~85	40~65	SH/T 0614 ^b
	Butane and advanced	≤2.5	—	—	
	Pentane and advanced	—	≤2.0	≤2.0	
	alkene	≤10	≤10	≤10	
	Butadiene (1,3butadiene)	≤0.5	≤0.5	≤0.5	
remainder	100ml remainder after evaporation ml	≤0.05	≤0.05	≤0.05	SY/T 7509
	Observe soiled-oil	pass	pass	pass	
density (20 ⁰ C) kg/m ³		actually measure	actually measure	actually measure	SH/T 0221 ^c
Sheet copper corrosion		≤1	≤1	≤1	SH/T 0232
Total sulfur content /(mg/m ³)		<270	<270	<270	SH/T 0222 ^d
sulphuretted hydrogen		zero	zero	zero	SH/T 0125
free water		zero	zero	zero	Eyeballing
1. gaseity content , total sulfur content is at 0 ⁰ C、101.35kPa. 2. can measure sample whether it exists free water by eyeballing when measuring density.					
a) evaporation pressure can be evaluated by GB/T 12576, measured by GB/T 6602 when arbitration. b) component can be measured by SH/T 0230, but measure by SH/T 0614 when arbitration. c) density can be measured by GB/T 12576,but measured by SH/T 0221 when arbitration. d) Total sulfur content can be measured by SY/T 7508, but measured by SH/T 0222 when arbitration.					

From : PRC STANDARD 《LPG IN VEHICLE》(GB 19159-2003)

Procedure of replacing LPG cylinder

(1) Take canvas glove to avoid the leaking gas to frostbite finger when gas changing.

(2) Make sure the place is clear and the air is ventilating when charging LPG, it is forbidden to smoke ,keep away from other naked flame

(3) Fill LPG as following: Lay the LPG cylinder flat, and set the charging limit valve upward, then screw off the dust cap on the charging valve, plug the filling connector, open the inlet shutoff valve to charge LPG till 80% rated volume of the container is full (the charging device is automatically closed when 80% rated volume of the container is full), take out the filling connector, screw down the dust cap and the charging limit valve.

Check all parts and make sure they are all at intact condition.

(4) Lift the cylinder up to truck, and fix it, let the arrow (①) be upward, then insert the fixed pin to cylinder.









Cylinder fixed way:

Metal belt bracket

The fixed way is opposite to disassemble way.



Buckle belt bracket

 <p>a. Hold strain device with right hand, take buckle belt with left hand, direct to the notch on ratchet wheel</p>	 <p>b. Pass buckle belt through the notch on ratchet wheel.</p>
 <p>c. Pull buckle belt downward with left hand, pull out the lock buckle with forefinger, middle finger and third finger in right hand, and push up to touch cylinder at the same time.</p>	 <p>d. Keep the buckle belt tensioning and keep the lock buckle out, revolve strain device downward with right hand till touch cylinder.</p>
 <p>e. Keep it tensioning with left hand, hold the strain device, loose lock buckle, and rotate strain device several times till it can not be pushed.</p>	 <p>f. Turn downward till touch cylinder.</p>

- (5) Make sure the inlet and outlet shutoff valve (② ③) are on closed state.
- (6) Connect the inlet connector (⑤) with outlet valve (④), and tighten.
- (7) Open outlet shutoff valve slowly (③).
- (8) Make sure there is no leaking before using, if there is some leaking, close outlet shutoff valve (③) in time, turn on the forklift input connector, (⑤).

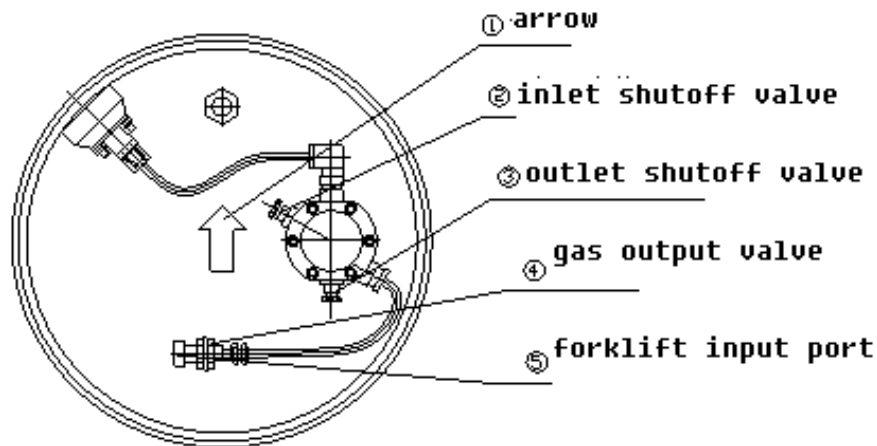

Notice : after installing cylinder, then connect the connecting pipe with quick connector, open outlet shutoff valve ③, smear every joint with soap bubble to check whether the joint is leaking, if there is leaking at joint, eliminate the problem, then fire forklift. Please close outlet shutoff valve ③ when the forklift is finishing working.

Notice during usage

- (1) When charging LPG assemble, at first open inlet shutoff valve, close outlet shutoff valve, when charge is done, close inlet shutoff valve.
- (2) When take assembly to the truck, it should be fixed and make the arrow direction upward, and inlet shutoff valve closed. Connecting inlet connector with assembly outlet port, and then revolve to tighten, open outlet shutoff valve, make sure it no leak, and convenient to use.
- (3) It must check the cylinder assembly whether leak or not per charging and fixing it on truck.
- (4) Please prevent dust to enter into the inlet, and revolve dustproof cover after filling LPG out to protect the airproof of check valve.
- (5) It is forbidden to change the pressure of safety valve.
- (6) Call the qualified unit to check and maintain, it is forbidden to repair by self. And keep apart the abnormal cylinder.
- (7) This assembly has 2 ways to fill LPG, one is volume and the other is weight. Weight: make sure the cylinder stand vertically when filling LPG. Volume: make sure the cylinder lay horizontally when filling LPG, and let the direction mark up.
- (8) Please obey the 《gas cylinder safe supervise rule》 awarded by the State Bureau of Quality and Technical Supervision when charging ,transporting, depositing ,using and inspecting.
- (9) When fixing and disassembling cylinder please do it lightly, it is forbidden to hit other object. Keep cylinder assembly intact and do not disassemble, adjust and replace components.
- (10) The LPG conform to GB11174 can be recharging; the maximum volume is no more than 80% of cylinder.
- (11) The LPG must be charging at the place awarded by qualified Quality and Technical Supervision Bureau, it is forbidden to charging by self
- (12) Charging unit must vacuumize or displace with nitrogen when the new or recheck cylinder is using at the first time.

- (13) Before reinstalling cylinder, lay the cylinder horizontal perpendicular to installing sign, close outlet shutoff valve, open inlet shutoff valve, see the finger of fluid indicator whether is lifting with the charging fluid when charging. Stop charging when the limit charging valve is working in time, and check whether the finger of fluid indicator is at the correct position. Close inlet shutoff valve after charging out.
- (14) Check the forklift truck fully ahead to ensure no leak of LPG, then open the LPG outpouring valve on the LPG cylinder, check more to ensure no leak of LPG fuel system before starting-up.
- (15) If there is LPG leak during operation, shut off the LPG switch and the outpouring valve at once, check every part and all connection to see if there is leak or loose, and get rid of it in time. Fuel by petrol before malfunction is removed.
- (16) If there is 10 minutes halt, you should shut off the LPG switch and the outpouring valve.
- (17) Cylinder must be avoiding under the blazing sun for quite a long time, and keep it far away from heat source, and forbidden to heat cylinder with heat source which the temperature is more than 40°C
- (18) It should have no less than 0.5% the cylinder volume to remain.
- (19) It is forbidden to modify cylinder mark and color sign.
- (20) Cylinder must be taken to the special unit per 5 years to inspect, the unit have qualification awarded by pressure vessel safety supervisor bureau.
- (21) Observe the level indication frequently during operation, if it is found that LPG consumption is not in proportion to working time, you should stop to check where is leakage, and shut off power, the LPG valve and all valves concerned at once to take good measure in time.
- (22) Park the truck at the shady and ventilated site; close the valves on the LPG cylinder. Never insolate the truck in the sun long.
- (23) Shut off power and all valves after the truck is garaged. Keep good ventilation and extinguishing measure in the garage.
- (24) Never repair the LPG cylinder, valves or pipes at garages or parking lots, any smoke on the truck.

Service & maintenance

1. This truck has been taken pressure trial and performance test before leaving factory. If there is performance failure, strictly forbid repairing without permission.
2. Close the valves on the LPG cylinder before disassembly and maintenance of the LPG device.
3. Suitably adjust the measure valve, for LPG consumption is changing with season.
4. Check and clean often the air cleaner and the LPG filter, replace it with a new one in time if there is any damaged.
5. After finishing the LPG forklift debugging and one day well run (or a full container of LPG is used up), you should adjust the LPG vaporizer again to ensure proper ratio of fuel to air.
6. Check the electric system after every three months have elapsed if any switch connection-peg is oxidized or rusted, and get rid of it in time.
7. Take a routine care for the whole LPG fuel system after every one year working, that is, clean the vaporizer, check airproof capacity of each tie-in in the high pressurized pipes and the low pressurized pipes.

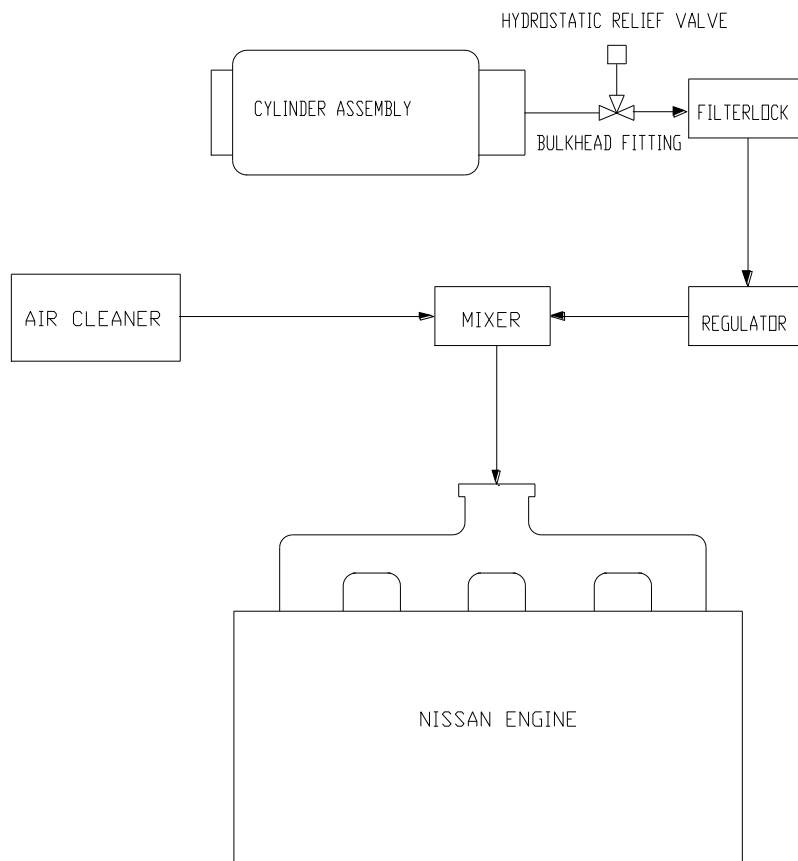

IMPCO single fuel system

14. Operational method of lead acid battery

1. Lead acid battery and its application

Lead acid battery is used for power start engine, and it can be for voltage regulation and overload generator substitute power, it has following strengths: low internal resistance, stable end voltage, large support current, low water cost, huge capacity, nice starting performance at low temperature, light pole corrosion, light mass, low fault rate, convenient maintenance. The Maintenance-free batteries are all sealed besides 2 vent holes (for overflowing a little air from battery) at the side of Maintenance-free battery. Low-maintenance lead-acid batteries left plus liquid mouth in the battery cover.

2. Storage and maintenance

1. Storage

The place for storing battery should be clean, dry, airy, and the battery should be charging every 3 months.

2. Maintenance

2. If truck will be stored over 30 days, the following should be done:

Maintenance-free battery

- 1) Insure the green point visual in inner capacity display;
- 2) Disconnecting negative earth wire to avoid discharging by additional current release;
- 3) Keep the battery charge completely if the battery can not be removed down from truck;
- 4) Make a general schedule, charge every 30-45 days;
- 5) Check battery when the green point of liquid densimeter at battery are invisible, then charge or replace battery;

When that did not see a battery hydrometer on the green point, the battery check, charge or replace batteries.

Low-Maintenance battery

- 1) Ensure that the battery electrolyte fluid level in the UPPER LEVEL.
- 2) Disconnecting negative earth wire to avoid discharging by additional current release;
- 3) Keep the battery charge completely if the battery can not be removed down from truck;
- 4) Make a general schedule, charge every 30-45 days;

5) When the liquid level below the LOWER LEVEL, please add pure water to the UPPER LEVEL, do not add more, otherwise vehicle and other components will be caused corrosion.

3. Notice for usage

Battery can produce explosive gas, electrolyte has corrosive, and the current can burn skin from battery producing, please flush immediately when electrolyte touch skin or eyes, then go to hospital if serious.

l) Human body, especially the head should be far away from battery, and the protected glass must be wearing.

1. Forbid battery emerging in naked fire or spark.
2. Connect active and negative pole with electrical equipment correctly to avoid burning battery or electrical equipment.
3. To avoid short circuit of battery, the electric things are forbidden to cover at battery.

4. Check the battery

Check the Maintenance-free battery

There is a little ball in battery capacity display, this ball can change its color as density of electrolyte changing, it is called electric eye. The ball will be green when the capacity is normal, density of electrolyte reaches the standard; it will be white when capacity is not enough, density of electrolyte does not reach the standard; it will be red when the electrolyte is acute shortage, the shell should be carefully examined whether there is rupture, leakage or battery failure.

Check the Low-Maintenance battery

As the forklift is used in a high temperature ambient ,and the battery easily consumes water, you should do pay attention to the liquid level when using the forklift. There is an aperture for adding liquid in the cover of the battery. Please add enough water up to the UPPER LEVEL when the liquid level is below the LOWER LEVEL and be sure the water is not so much that can spill out to erode your forklift.

When lacking of the electrolyte, please check whether the surface is damaged or leaky, or the battery is conking out.

15. Use, installation and safety rules of attachment

HANGCHA will choose attachment that according with International standard ISO2328 《Forklift pothook fork and install size of carriage》, such as clamp, rotator, paper roll clamp, carrying ram, side-shifter etc.

1、 Attachment use.

(1) Know well the content of nameplate on attachment, read the instruction manual before

Usage.(Especially the manual from attachment company)Before operate the attachment, the people should be trained and obtain the qualification.

(2) It should be understand the basic capability and operate methods of attachment. Especially the admit load, lift height, size of cargo and adapt range of attachment.

(3) Operate the multi-functional attachment, such as with side-shifter, clamp or rotator, it is not allowed that two action at one time. Operate one functional then do another one.

(4) Prohibit the cargo at a high position when truck move with attachment. If the size of cargo is too big, prohibit the truck move on. Transport the cargo, make sure that the distance of bottom of cargo and ground is less than 300mm and mast incline back.

(5) The weight of cargo couldn't exceed the limited value of combination carrying capacity of forklift and attachment. It is not allowed that partial load at high position. It is a short time work for attachment with side-shifter. Partial load is around 100mm (Above 5 ton (including 5 ton), the side-shifter movable within 300mm.

(6) In the range of the projection forth 2m of the lower of attachment and cargo, prohibit stand to avoid the suddenness except the driver position under overhead.

(7) It is not allowed that an emergency brake in moving. Run slowly with load.

(8) Prohibit outside force when attachment working.

(9) It couldn't be use at malfeasance situation and overstep normal work range

(10) When the attachment failure, prohibit use without check.

Check and maintenance:

(1) Check the clearance of carriage beam and below catch of attachment if accord the attachment manual.

(2) Check the rise catch is right on the flute of fork carriage.

(3) Use the auto currency lithic-grease per 500 hours to bearing surface.

(4) If the tighten firmware become flexible.

(5) Check the tie-in of hydraulic pressure loop, if tube attaint. Prohibit use after repair.

(6) Check the drive of attachment timing or turn the component if fray or block, change betimes.

(7) Check each element if in normal under load attachment is work in gear. If not, check the hydraulic pressure loop, find out the broken part, change air poof or whole loop part.

2、 Attachment assembly

Caution

- 1、 Untempered technology licence of our company, any refit at safety and capability to attachment is strict prohibit.
- 2、 Fact rating load capacity should be the least of rating load capacity, the load capacity of attachment, colligate load capacity of truck. Generally speaking, the colligate load capacity of truck is the least. Attachment load capacity just a count value of attachment pressure.
- 3、 Assembly go to in reason, credibility, safety to avoid the attachment glide around carriage in using.
- 4、 After hang attachment, embed the rise catch block to the gap of top beam, let the offset of centre line of attachment and carriage is less than 50mm. Otherwise, it will be affect the landscape orientation stability of forklift.
- 5、 To these attachment with rotating function, such as paper roll clamp, bale clamp, muti-purpose clamp, drum clamp, it needs to weld chock block in the joint of carriage beam and attachment to prevent move from side to side in the operation.
- 6、 Assembly the attachment of below catch orientation, it need to adjust the clearance between below catch and beam of carriage.

16. Related safety instruction and standard (for trucks exporting to Europe or option)

The model by CE certification which according to the following instruction and standard: DIRECTIVE 2006/42/EC OF THE EUROPEAN PAMENT AND OF THE COUNCIL, DIRECTIVE 2000/14/EC OF THE EUROPEAN PAMENT AND OF THE COUNCIL, EN1726-1:1998(Engineering Industry truck safety standardize), EN12053:2001, EN1175-2:1998, EN13059:2002 coordinate standard.

- Main safety factor will be according with DIRECTIVE 2006/42/EC OF THE EUROPEAN PAMENT AND OF THE COUNCIL and EN1726-1:1998、EN1175-2:1998 standard.
- Noise will accord with EN12053:2001 and 2000/14/EC.

	Model	The sound pressure level at operator position unit: dB(A)	Sound radiation sound power level unit : dB(A)
The noise in the operator's position is in pressure level, and radiated noise is in power level. Noise emission according to EN12053	CPYD10N-RW	85.2	102.8
	CPYD15N-RW	85.2	101.7
	CPYD18N-RW	85.7	101.9
	CPYD20N-RW	87.1	102.8
	CPYD25N-RW	87.1	102.9
	CPYD30N-RW	85.9	103.1
	CPYD35N-RW	85.5	103.4
	CPQD10N-RW	85.2	101.9
	CPQD15N-RW	85.2	102.1
	CPQD18N-RW	85.7	102.5
	CPQD20N-RW	87.1	103.0
	CPQD25N-RW	86.5	103.3
	CPQD30N-RW	85.6	103.4
	CPQD35N-RW	86.5	103.4
	CPCD10N-RW	87.4	103.2
	CPCD15N-RW	87.8	103.2
	CPCD18N-RW	88.5	103.3
	CPCD20N-RW	88.1	103.1
	CPCD25N-RW	87.4	103.0
	CPCD30N-RW	88.7	103.2
CPCD35N-RW	88.8	103.4	

- Vibration parameters will be accord with ISO5349-2:2001、EN13059:2002.

Model	Synthetic acceleration from the seat to the operator body unit: m/s ²	Model	Synthetic acceleration from the seat to the operator body unit: m/s ²
CPYD10N-RW	1.54	CPQD25N-RW	1.54
CPYD15N-RW	1.52	CPQD30N-RW	1.48
CPYD18N-RW	1.52	CPQD35N-RW	1.52
CPYD20N-RW	1.48	CPCD10N-RW	1.54
CPYD25N-RW	1.48	CPCD15N-RW	1.53
CPYD30N-RW	1.48	CPCD18N-RW	1.54
CPYD35N-RW	1.52	CPCD20N-RW	1.48
CPQD10N-RW	1.50	CPCD25N-RW	1.50
CPQD15N-RW	1.50	CPCD30N-RW	1.46
CPQD18N-RW	1.52	CPCD35N-RW	1.50
CPQD20N-RW	1.48		

- Electromagnetism compatible is measured according to EN12895:2000, and the result meets the requirement of 2004/108/EEC.
- Engine emission is according to standard: 97/68/EC and **2005/88/EC**.



杭叉集团股份有限公司

HANGCHA GROUP CO., LTD.

地址: 杭州市石桥路 398 号 邮编: 310022
Add: 398 Shi Qiao Road, Hangzhou 310022
Tel: +86-571-88926666

Website: <http://www.zjhc.cn>
E-Mail: sales@zjhc.cn
Fax: +86-571-88144682

EC DECLARATION OF CONFORMITY

MANUFACTURE

Name: Zhejiang Hangcha Engineering Machinery Co., Ltd.
Address: 398 Shiqiao Road, Hangzhou 310022, P. R. China

THE TECHNICAL DOCUMENTATION WAS COMPILED BY:

Name:
Address:

Post:

HEREBY DECLARES THAT THE PRODUCT DESCRIBED BELOW:

Description: Industrial truck – Counterbalanced Lift truck

Model:

Serial number: Net engine kW
power:

Manufacturing
year:

COMPLIES WITH THE PROVISIONS OF THE FOLLOWING EUROPEAN DIRECTIVES:

2006/42/EC Machinery Directive
2004/108/EC EMC Directive
97/68/EC Engine pollutant emission Directive

2000/14/EC & 2005/88/EC Noise Directive

Equipment according to the definition given by Annex I, item 36 of Noise Directive.

Conformity assessment procedure followed: Annex V of Noise Directive 2000/14/EC

Holder of the technical documentation

Name:

Address:

Measured sound power dB Guaranteed sound power dB
level: level:

COMPLIES WITH THE PROVISIONS OF THE FOLLOWING HARMONIZED STANDARDS:

EN 1726-1 Safety of industrial trucks - Self-propelled trucks up to and including 10 000 kg capacity and industrial tractors with a drawbar pull up to and including 20 000 N

Annex I of Machinery Directive 2006/42/EC Essential health and safety requirements relating to the design and construction of machinery

Done at
(place):

On (date):

Name of the
signatory:

Title:

Signature: _____



杭叉集团股份有限公司

HANGCHA GROUP CO., LTD.

地址: 杭州市石桥路 398 号 邮编: 310022
Add: 398 Shi Qiao Road, Hangzhou 310022
Tel: +86-571-88926666Website: <http://www.zjhc.cn>
E-Mail: sales@zjhc.cn
Fax: +86-571-88144682**EC DECLARATION OF CONFORMITY****MANUFACTURE**Name: Zhejiang Hangcha Engineering Machinery Co., Ltd.
Address: 398 Shiqiao Road, Hangzhou 310022, P. R. China**THE TECHNICAL DOCUMENTATION WAS COMPILED BY:**Name:
Address:
Post:**HEREBY DECLARES THAT THE PRODUCT DESCRIBED BELOW:**

Description: Industrial truck – Counterbalanced Lift truck

Model:

Serial number: Net engine kW
power:Manufacturing
year:**COMPLIES WITH THE PROVISIONS OF THE FOLLOWING EUROPEAN DIRECTIVES:**2006/42/EC Machinery Directive
2004/108/EC EMC Directive**2000/14/EC & 2005/88/EC Noise Directive**

Equipment according to the definition given by Annex I, item 36 of Noise Directive.

Conformity assessment procedure followed: Annex V of Noise Directive 2000/14/EC

Holder of the technical documentation

Name:

Address:

Measured sound power dB Guaranteed sound power dB
level: level:**COMPLIES WITH THE PROVISIONS OF THE FOLLOWING HARMONIZED STANDARDS:**

EN1726-1 Safety of industrial trucks - Self-propelled trucks up to and including 10 000 kg capacity and industrial tractors with a drawbar pull up to and including 20 000 N

Annex I of Machinery Directive 2006/42/EC Essential health and safety requirements relating to the design and construction of machinery

Done at Name of the signatory:

(place): Title:
On date): Signature: _____

17. Maintain record

Date	Item of maintenance	Maintain personnel



HANGCHA GROUP CO. , LTD.

- Address For: OVERSEAS USERS
- Manufacturing Site: 88 Donghuan Road, LinAn Economic Development Zone,
Hangzhou, P.R. of China ■ ZIP:311305
- Registered Address: 398 Shi Qiao Road, Hangzhou, P.R. of China ■ ZIP:310004
- Fax: 0086-571-88926789 0086-571-88132890
- Web: <http://www.hcforlift.com>
- E-mail: sales@hcforlift.com