

macchine edili ed agricole
d DIECI

Hercules 160.10

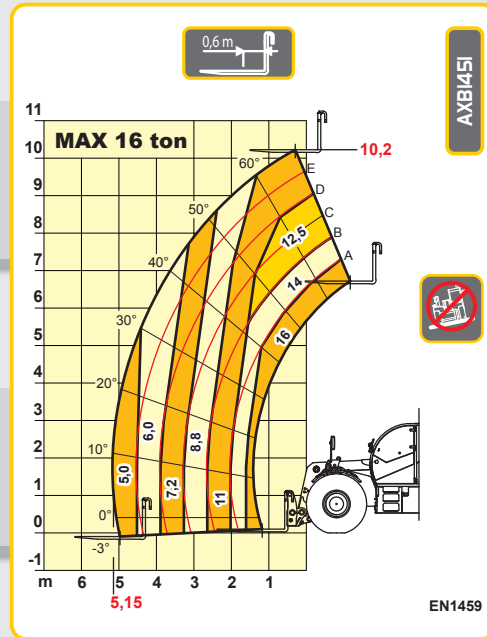

Hercules 160.10



PERFORMANCES

Maximum capacity:	16,000 kg
Capacity at maximum height on tyres:	11,000 kg
Capacity at maximum boom extension on tyres:	5,000 kg
Maximum lifting height on tyres:	10.20 m
Maximum horizontal boom extension:	5.15 m
Boom extension at maximum height:	0.30 m
Fork tilting angle:	120°
Tearing force:	16,200 daN
Maximum allowable slope with load:	35 %
Total empty weight:	23,700 kg
Max speed*:	25 km/h

* = referred to wheels having the maximum allowable diameter



TRANSMISSION

Transmission: hydrostatic with variable delivery pump
 Hydraulic engine: with automatic adjustment
 Reversing gear: electro - hydraulic
 Inching pedal for controlled forward movement.
 Servocontrolled 2-speed gear box.



HYDRAULIC SYSTEM

Gear Pump: 53 l/1' / 200 bar
 Variable delivery pump (Load Sensing): 170 l/1' / 350 bar
 Control valve with joystick: 4 in 1
 Simultaneous movements: 4
 Proportional control distributor "Load Sensing" with "Flow Sharing"



DIFFERENTIAL AXLES (HEAVY DUTY)

Steering axles: 2, with planetary reduction gears
 Type of steering: 4 wheels / transversal / 2 wheels
 Front axle: levelling
 Rear axle: oscillating
 Service brake: oil bath on the 4 wheels
 Negative parking brake.



ENGINE

PERKINS 1106D-ETA - 146 kW
 Maximum power: 146 kW (196 hp) at 2,200 rpm
 Type: four-stroke, diesel engine, Common-Rail
 Cylinders number and layout: 6, vertical in line
 Displacement: 6,598 cm³ -Turbo compressor aftercooler
 Cooling system: liquid
 Specific fuel consumption (2,200 rpm): 230g/kWh
 Electronic accelerator.
 Manual accelerator.
 Air pre-heater for cold climates.



REFUELLING (litre)

Oil tank: 300
 Fuel tank: 270



STANDARD DEVICES

Anti-tipping device with block for hazardous movements.
 Hydraulic socket for possible accessories on boom head.
 ROPS-FOPS approved closed soundproof cab with heating and opening roof.
 Grammer deluxe seat.
 High efficiency cyclone self-cleaning air filter.



TYRES

Tyres: 18.00 R25



OPTIONAL AND ACCESSORIES

A/C; Webasto heater; digital speedometer; water heater; pneumatic seat suspension; light on boom head; quick attachment for accessories; radio; anti-theft alarm; glass protection; Reversible fan.
 (For further customised accessories, please consult your local dealer)

SYMBOLS KEY

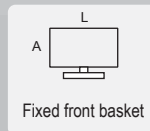
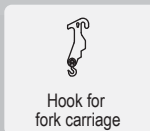
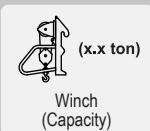
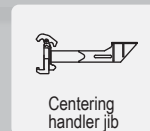
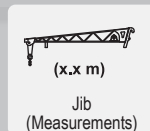
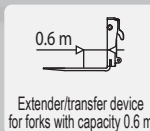
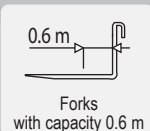

Equipment

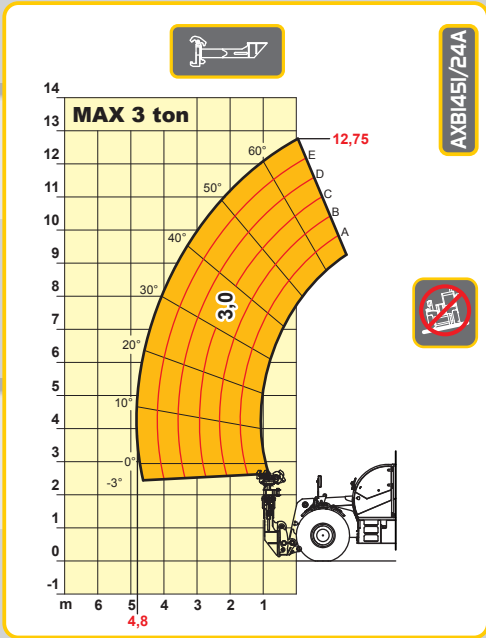
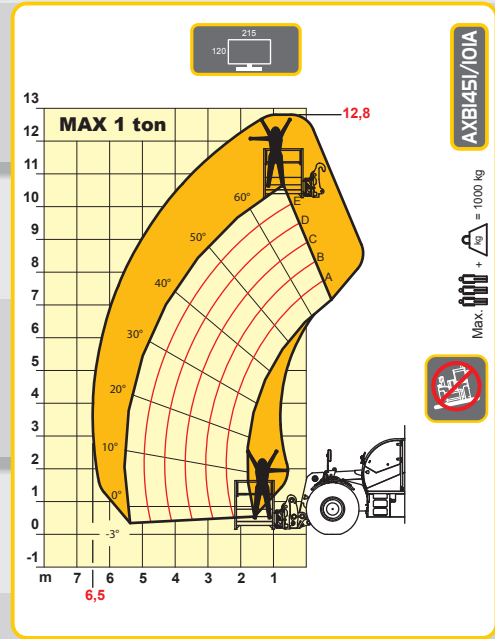
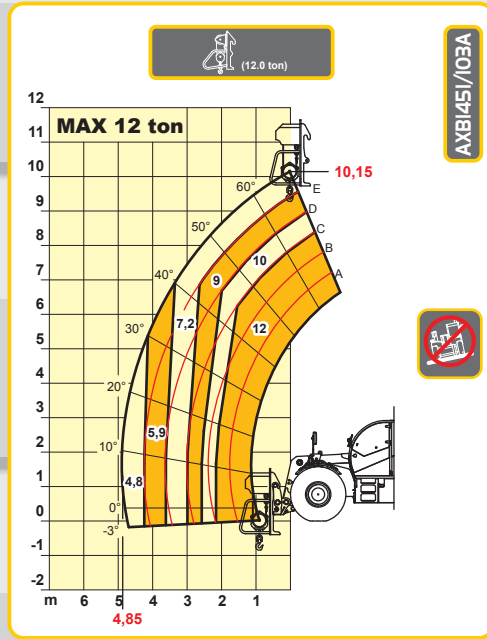
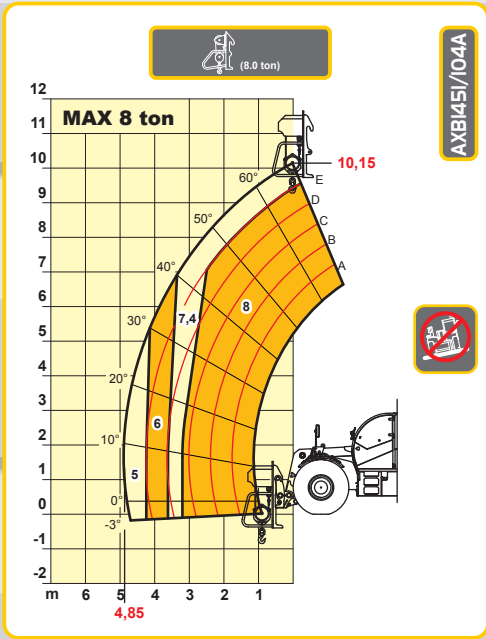
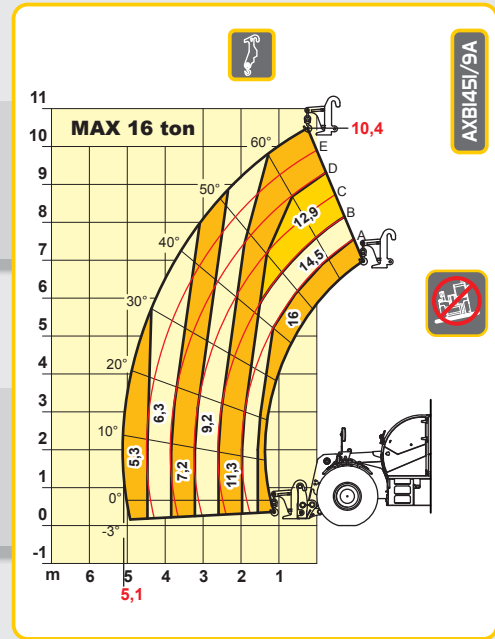
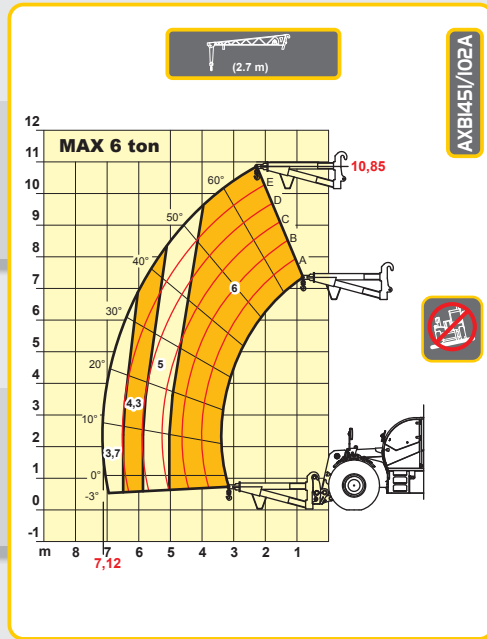
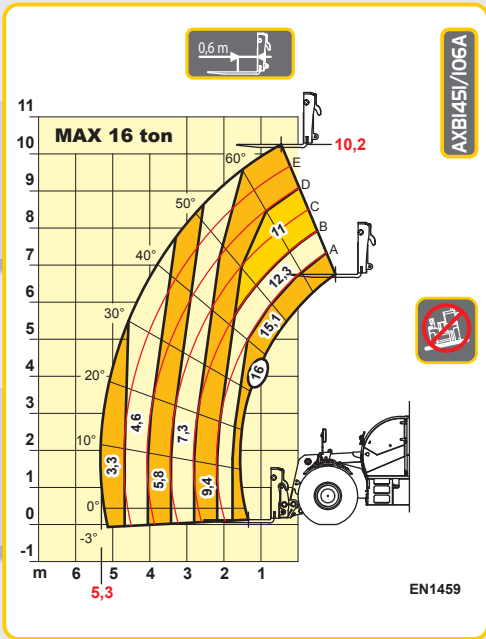

Hercules 160.10

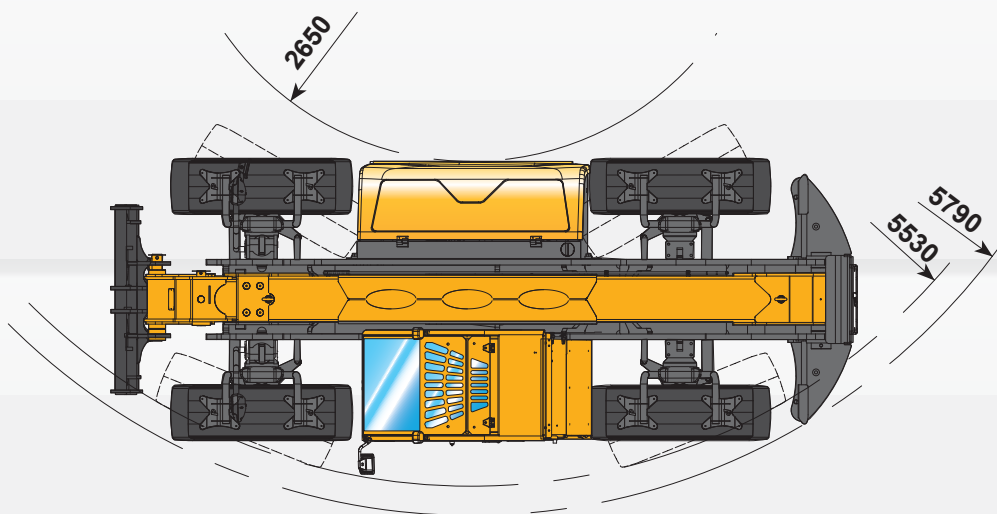
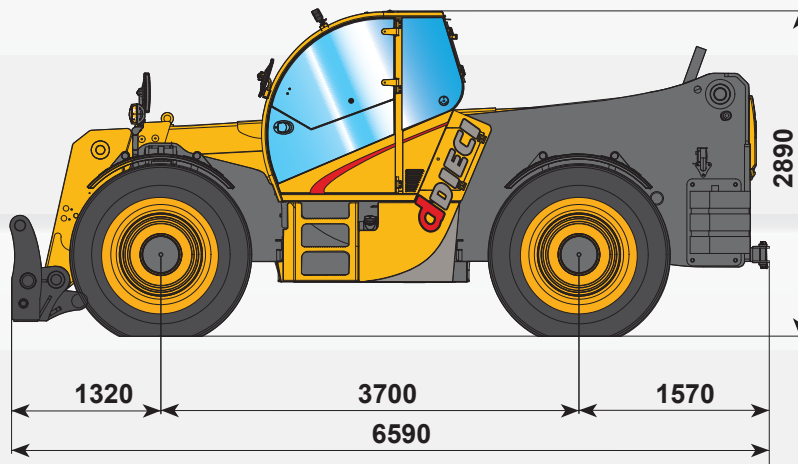
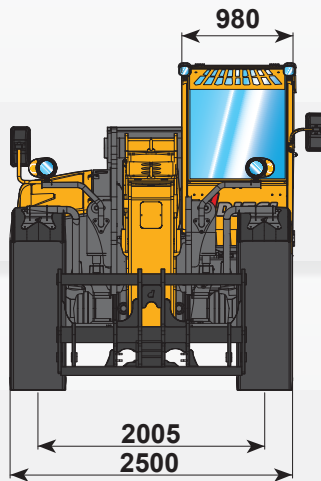

I dati contenuti in questo stampato sono forniti a titolo indicativo; i modelli descritti sono suscettibili di modifiche, senza preavviso, da parte del costruttore, disegni e fotografie possono riferirsi a equipaggiamenti opzionali o ad allestimenti destinati ad altri paesi. Per ogni altra informazione, rivolgersi alla sede DIECI all'indirizzo a fondo scheda.
The information contained in the present publication is only intended as an indication; the models described may be modified, without notice, by the manufacturer, drawings and photographs may refer to optional equipment or to particular specifications for other countries. For any further information, please contact DIECI headquarters at the address given below.