

macchine edili ed agricole  
**d DIECI**

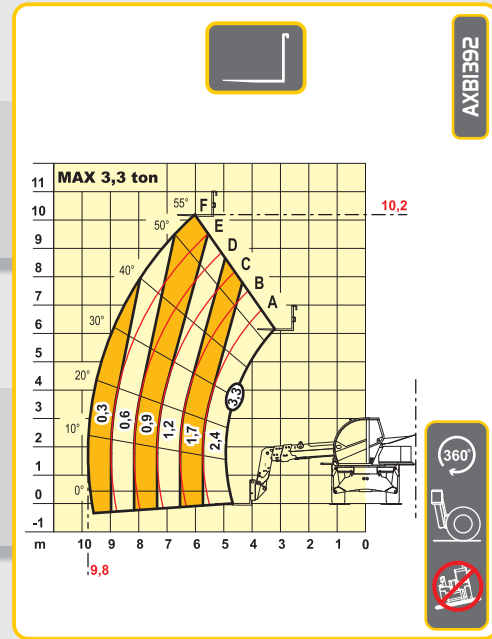

**Pegasus 60.16**

# Pegasus 60.16

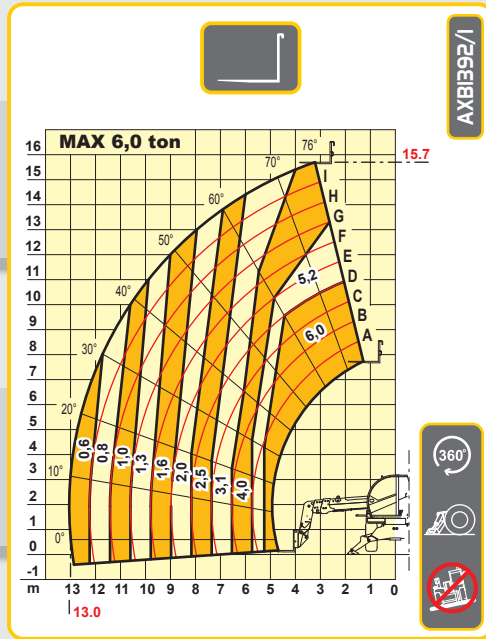
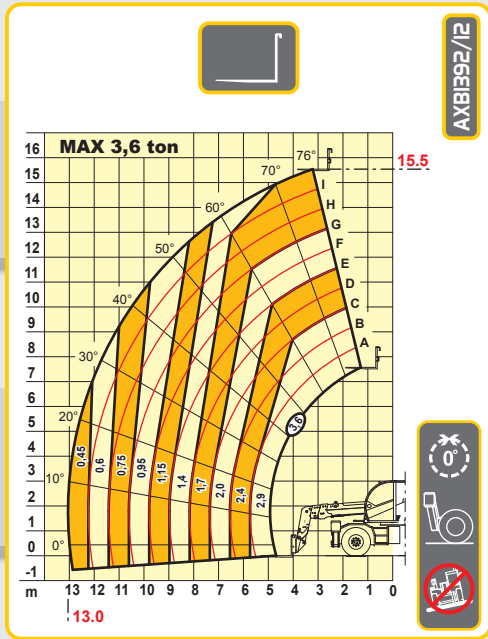

## PERFORMANCES

- Maximum capacity:..... 6.000 kg
- Capacity at maximum height on stabilizers:..... 4.000 kg
- Capacity at maximum height on tyres:..... 1.700 kg
- Capacity at maximum boom extension on stabilizers:..... 600 kg
- Capacity at maximum boom extension on tyres:..... 450 kg
- Maximum lifting height on stabilizers:..... 15,70 m
- Maximum lifting height on tyres:..... 15,50 m
- Maximum horizontal boom extension:..... 13,00 m
- Boom extension at maximum height:..... 3,20 m
- Fork tilting angle:..... 134°
- Tearing force:..... 5.700 daN
- Towing force:..... 9.000 daN
- Maximum allowable slope:..... 40 %
- Total empty weight:..... 16.600 kg
- Max speed (referred to wheels having the maximum allowable diameter):..... 40 km/h

## TRANSMISSION

- Transmission:..... Hydrostatic with variable delivery pump
- Hydraulic engine:..... with automatic adjustment
- Reversing gear:..... Electro - hydraulic
- Inching pedal for controlled forward movement
- Servocontrolled 2 speed gearbox

## HYDRAULIC SYSTEM

- Double gear pump with "Energy Saving" system
- Gear pump with capacity at max speed:..... 135 lt/1'
- Max working pressure:..... 230 bar
- Control valve with joystick:..... 5 in 1 proportional
- Simultaneous movements:..... 5
- Proportional control distributor "Load Sensing" with "Flow Sharing"

## DIFFERENTIAL AXLES

- Steering axles:..... 2, with planetary reduction gears
- Type of steering:..... 4 wheels / transversal / 2 wheels
- Front axle:..... levelling
- Rear axle:..... oscillating
- Service brake:..... oil bath on the 4 wheels with double hydraulic system and servo brake
- Negative parking brake.

## ENGINE

- PERKINS 1104D-ETA - 106 kW
- Power:..... 106 kW (144 hp) at 2200 rpm
- Type:..... four-stroke engine, diesel, Common-Rail
- Cylinders number and layout:..... 4, vertical in line
- Displacement:..... 4399 cm<sup>3</sup> -Turbo compressor aftercooler
- Cooling system:..... liquid
- Specific fuel consumption per hour (2.200 rpm):..... 230g/kWh
- Electronic accelerator.
- Manual accelerator.
- Air pre-heater for cold climates.

## REFUELLING (litre)

- Hydraulic tank:..... 270
- Fuel tank:..... 180

## STANDARD DEVICES

- Anti-tipping device with block for hazardous movements.
- Continuous turret rotation over 360°.
- Oscillation block on rear axle.
- Hydraulic socket for possible accessories on boom head.
- ROPS-FOPS approved closed soundproof cab with heating and opening roof.
- Stabilizers with joystick control
- Grammer deluxe seat.
- High efficiency cyclone air filter.
- Self-blocking rear axle (Limited Slip)

## OPTIONAL AND ACCESSORIES

- A/C; Webasto heater; digital speedometer; water heater;
- pneumatic seat suspension; light on boom head; quick attachment for accessories; radio; anti-theft alarm; glass protection; Transverse levelling device on wheels and others...
- (For further customised accessories, please consult your local dealer)

## TYRES

- Tyres:..... 18 - R22,5" (Industrial)
- Alternative:..... 18 - R22,5" (Agricultural)

### SYMBOLS KEY

Negative jib	Extendable three-sided basket	Jib (Measurements)	Centering handler jib	360° Continuous rotation	0° Front position	Stabilizers raised	Forks
Positive jib	Three-sided fixed basket	Winch (Capacity)	Fork-carrying plate hook	400° Non-continuous rotation	Do not work on tyres	Stabilizers lowered	DO NOT maneuver if the machine is NOT levelled

# Equipment

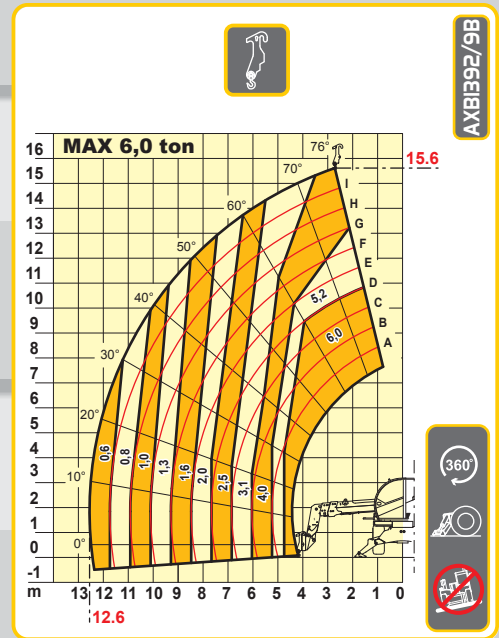
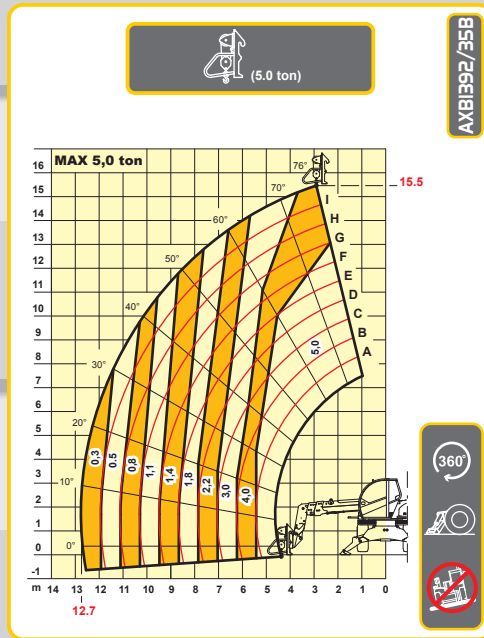
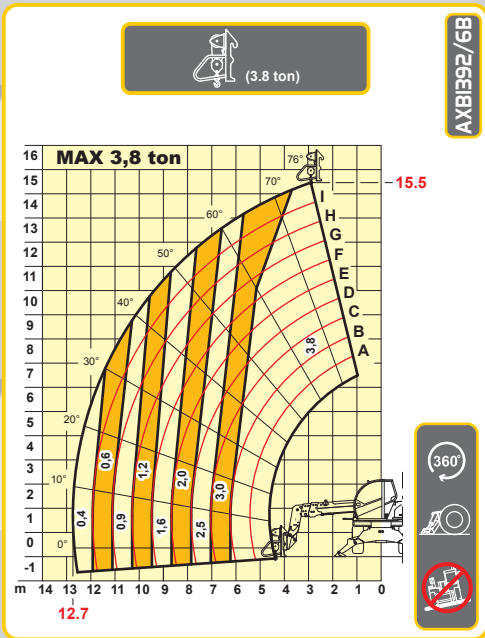
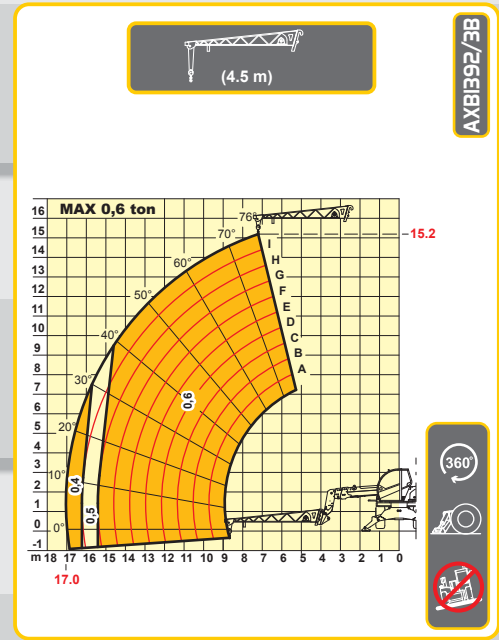
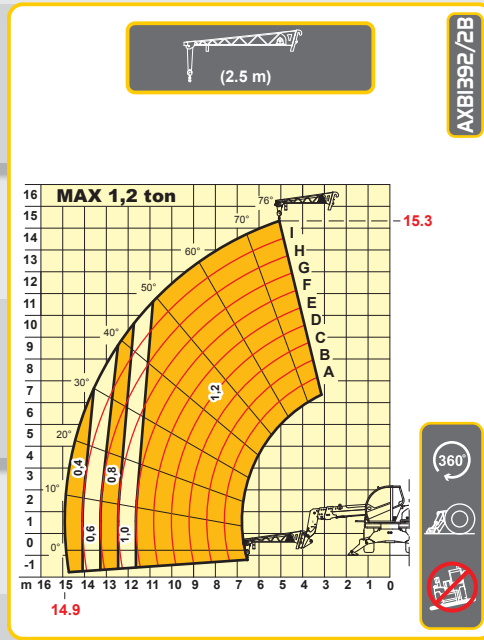
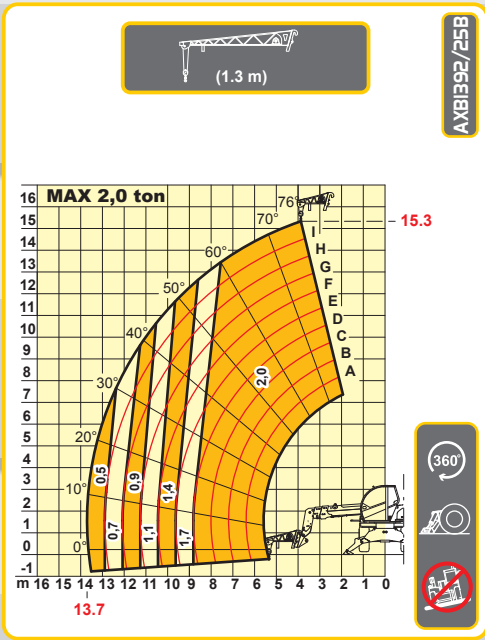
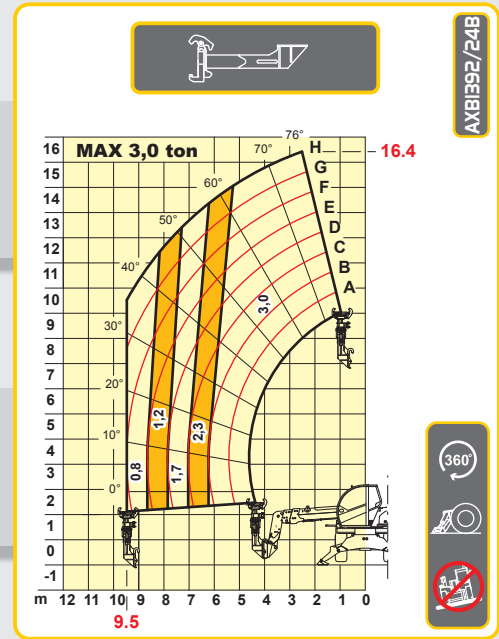
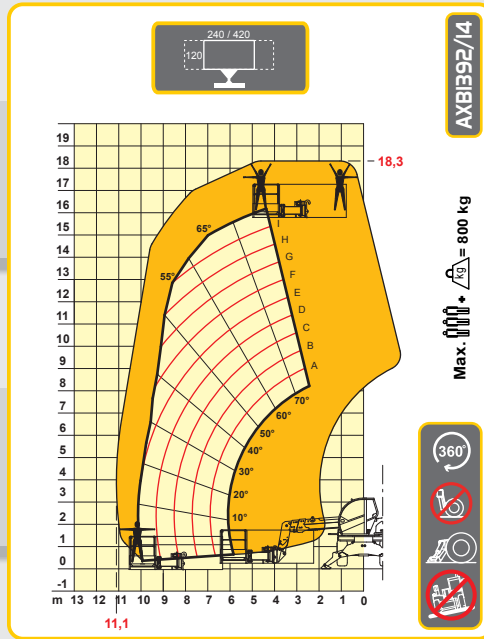
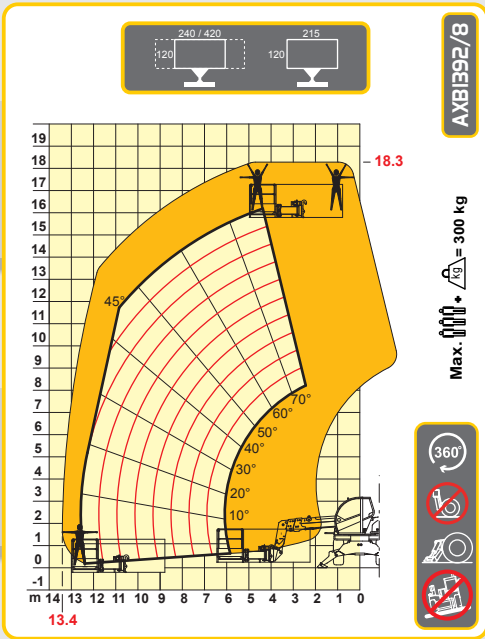



# Pegasus 60.16

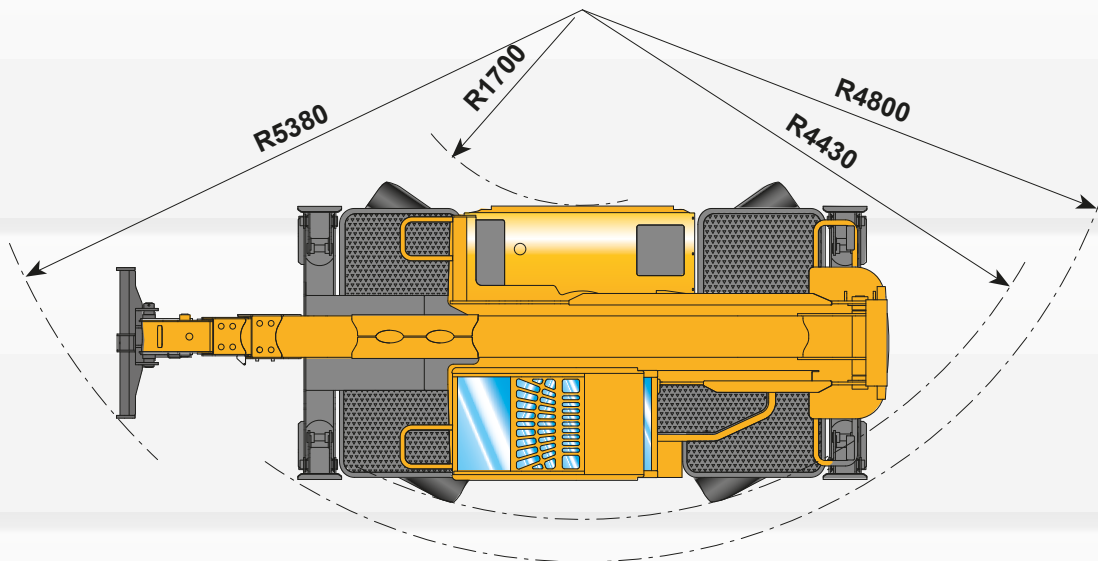
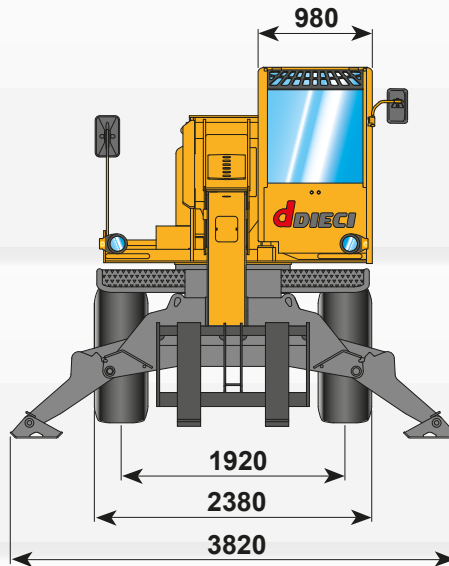
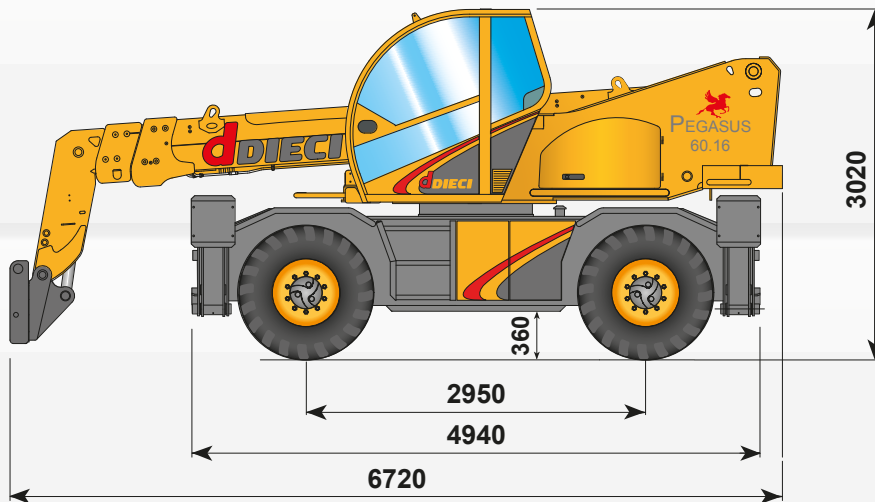

I dati contenuti in questo stampato sono forniti a titolo indicativo; i modelli descritti sono suscettibili di modifiche, senza preavviso, da parte del costruttore, disegni e fotografie possono riferirsi a equipaggiamenti opzionali o ad allestimenti destinati ad altri paesi. Per ogni altra informazione, rivolgersi alla sede DIECI all'indirizzo a fondo scheda.

The information contained in the present publication is only intended as an indication; the models described may be modified, without notice, by the manufacturer, drawings and photographs may refer to optional equipment or to particular specifications for other countries. For any further information, please contact DIECI headquarters at the address given below.