

Operating Instructions Parts List



TF30 and TF50 Lift Table

Note: Owner and operator **MUST** read and understand this operating instructions before use this lift table.

Thank you for using this lift table. Your lift table is made of high quality steel and is designed for the horizontal lifting and transport of loads on a level, fixed base. For your safety and correct operation, please carefully read this instruction before using it and keep it on file for future reference.

NOTE: All of the information reported herein is based on data available at the moment of printing. We reserves the right to modify our own products at any moment without notice and incurring in any sanction. So, it is suggested to always verify possible updates.

1. WARNINGS

1. DO NOT put foot or hand in scissors mechanism.
2. DO NOT allow other person to stand in front or behind lift table when it is moving.
3. DO NOT move lift table when table is in raised position. Load could fall down.
4. DO NOT enter under table.
5. DO NOT overload lift table.
6. DO NOT put foot in front of rolling wheels, Injury could fall down.
7. WATCH difference of floor level when moving lift table. Load could fall down.
8. DO NOT use lift table on slope or inclined surface, lift table may become uncontrollable and create danger.
9. DO NOT lift people. People could fall down and suffer severe injury.

2. CAUTION

1. Read this operation manual carefully and understand completely operating lift table. Improper operation could create danger.
2. This lift table is a movable lifter designed to lift or lower rated load on table. DO NOT use lift table for other purpose than its intended use.
3. DO NOT allow person to operate lift table that dose not understand its operation.
4. DO NOT lower table too fast. Load could fall down and create danger.
5. KEEP watching the condition of load. Stop operating lift table if load becomes unstable.
6. Braking lift table when sliding load on or off table.
7. DO NOT side or end load. Load must be distributed on at least 80% of table area.
8. DO NOT use lift table with unstable, unbalanced loosely load.
9. Practice maintenance work according to service instructions.
10. DO NOT modify lift table without manufacturers written consent.
11. REMOVE load from table and use safety stopper to prevent table from lowering when servicing lift table.
12. This lift table is not designed to be water resistant. Use lift table under dry condition.

3. DAILY INSPECTION

Daily inspection is effective to find the malfunction or fault on lift table. Check lift table on the following points before operation .

- (1) Check for scratch, bending or cracking on the lift table.
- (2) Check if there is any oil leakage from the cylinder.
- (3) Check the vertical creep of the table.

- (4) Check the smooth movement of the wheels.
- (5) Check the function of brake.
- (6) Check if all the bolts and nuts are tightened firmly.

CAUTION: DO NOT use lift table if any malfunction or fault is found.

4. OPERATING LIFT TABLE

4-1. How to use the brake.

CAUTION: Brake lift when not moving it in order to prevent sudden movement.

The brake is equipped with the swivel caster on the right side.

- (1) Brake the wheel, press the brake pedal.
- (2) Release the brake, lift up the brake pedal.

4-2. Lifting the table

WARNING

1. DO NOT overload lift table. Stay within its rated capacity.
2. DO NOT side or end. Load must be distributed on at least 80% of table area.

Press the lifting pedal several times until the table reaches the desired position. The table does not elevate after reaching the highest position even if the lifting pedal is pressed. The table lowers slightly after reaching the highest position.

MAXIMUM CAPACITY OF TABLE	
TF 30	TF 50
300Kg	500Kg

NOTE:

The hydraulic cylinder is designed to hold table. As is the nature of hydraulic system, table lowers very slowly over and extended period of time. Please note the table does not stay at the same position indefinitely.

4-3. Lowering table

WARNING: DO NOT put foot or hand in scissors mechanism

- Knob rotating makes table down..

5. Specifications

Model	Capacity (kg)	Table (Mm)	Table Height (mm)	Wheel (Mm)	Weight (Kg)
TF30	300	815×500/850×500	285-880	Φ 125	77
TF50	500	815×500/850×500	285-880	Φ 125	81

6. Service Instructions

6-1. Lubricate each point described below every month:

6-2. Change hydraulic oil every 12 months.

Lubricating Points

- (1) Fitting of cylinder---Oil
- (2) Roller friction surface---Grease
- (3) Link pin ---Oil
- (4) Pedal fitting point---Oil
- (5) Grease nipple---Grease

7. Part List of Table

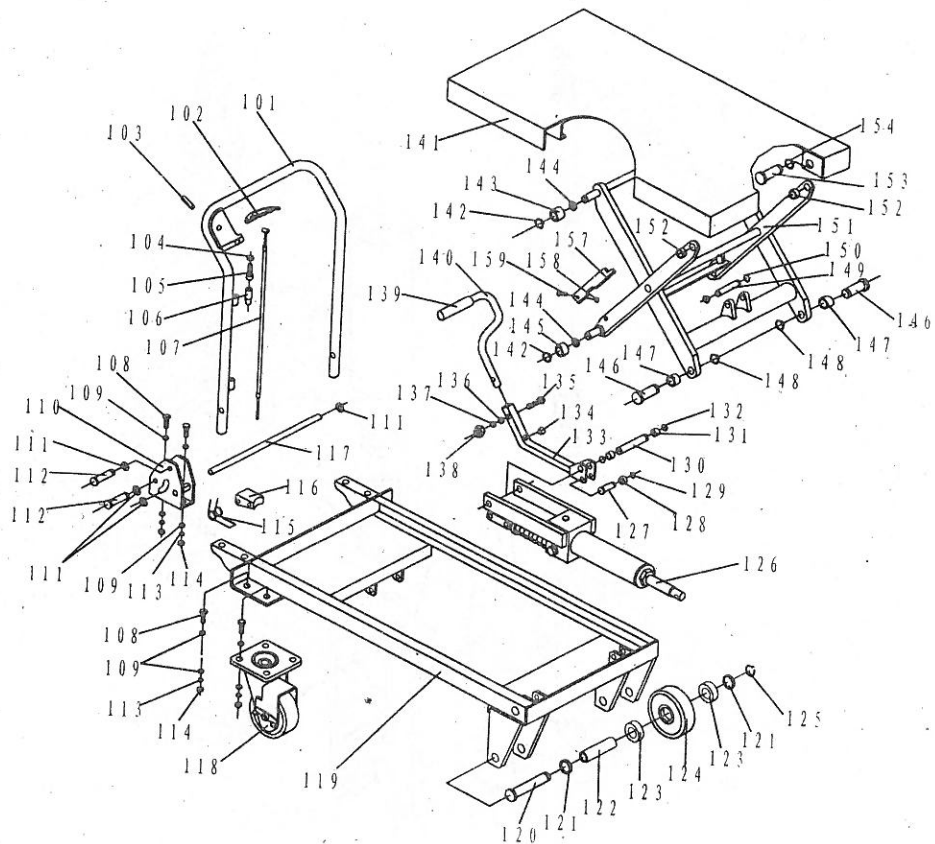

No		Qty.	No	Description	Qty.
101	Handle Grip	1	130	Pin	1
102	Control Handle	1	131	Washer	2
103	Elastic Pin	1	132	Retaining Ring	2
104	Nut	1	133	Connecting Rod	1
105	Bolt with Hole	1	134	Cushion	1
106	Jacket	1	135	Bolt	1
107	Pull Rod	1	136	Washer	1
108	Bolt	12	137	Elastic Washer	1
109	Washer	12	138	Nut	1
110	Seat of Grip	2	139	Protecting Cover	1
111	Retaining Ring	6	140	Pedal Bar	1
112	Pin	4	141	Table	1
113	Elastic Washer	12	142	Retaining Ring	6
114	Nut	12	143	Roller	2
115	Spring	2	144	Washer	4
116	Cushion	2	145	Roller	2
117	Long Shaft	1	146	Pin	2
118	Universal Wheel	2	147	Bushing	2
119	Frame	1	148	Retaining Ring	2
120	Pin	2	149	Pin	1
121	Washer	4	150	Retaining Ring	2
122	Axle	2	151	Fork Arm	1
123	Bearing	4	152	Bushing	2
124	Wheel	2	153	Pin	2
125	Retaining Ring	2	154	Retaining Ring	2
126	Pump Unit	1	156		
127	Pin	1	157	Support Plank	2
128	Washer	1	158	Screw	2
129	Retaining Ring	2	159	Nut	2

8. Part List of Pump

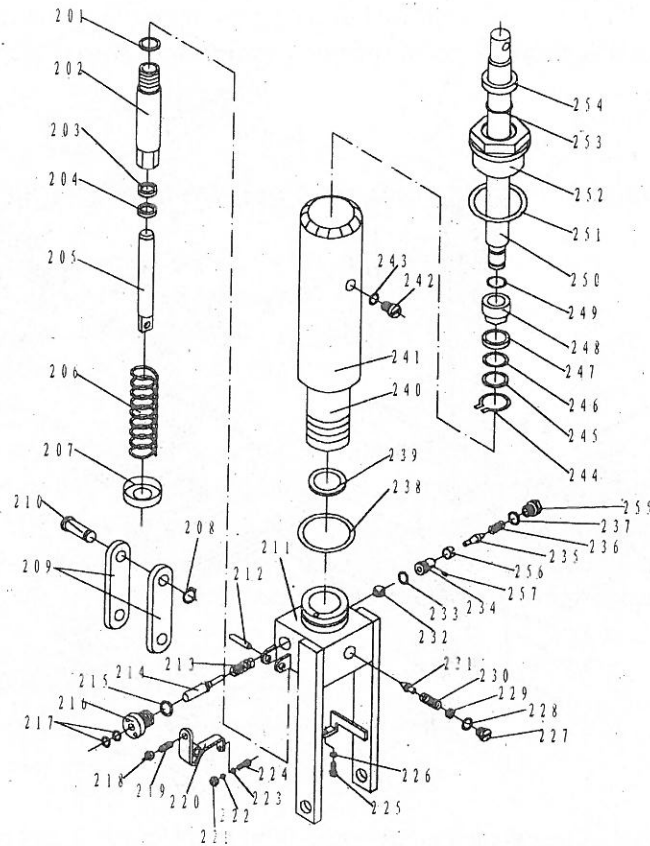

No	Description	Qty.	No	Description	Qty.
201	Seal Washer	1	230	Spring	1
202	Pump Cylinder	1	231	Spindle of Safety Valve	1
203	Dust Ring	1	232	Steel Ball	1
204	Y - Seal	1	233	O - Ring	1
205	Pump Piston	1	234	Seat of Pumping Valve	1
206	Spring	1	235	Spindle of Pumping Valve	1
207	Spring Cap	1	236	Spring	1
208	Retaining Ring	1	237	Seal Washer	1
209	Joint Plate	2	238	O - Ring	1
210	Pin	1	239	Seal Washer	1
211	Pump Body	1	240	Cylinder	1
212	Elastic Pin	1	241	Housing	1
213	Spring	1	242	Bolt	1
214	Strike Pin	1	243	Seal Washer	1
215	Seal Washer	1	244	Retaining Ring	1
216	Axle Sleeve	1	245	Washer	1
217	O - Ring	2	246	O - Ring	1
218	Nut	1	247	Cup Packing	1
219	Screw	1	248	Piston	1
220	Lever Plate	1	249	O - Ring	1
221	Nut	1	250	Piston Rod	1
222	Elastic Washer	1	251	Seal Washer	1
223	Washer	1	252	Cylinder Cap	1
224	Bolt with Hole	1	253	O - Ring	1
225	Bolt with Hole	1	254	Dust Ring	1
226	Nut	1	255	Plug	1
227	Plug	1	256	Liquid Throttle Sheath	1
228	O - Ring	1	257	Bolt	1
229	Adjusting Bolt	1			