

Electric Pallet Truck

With capacity of 1,500 to 2,000kg

- / The truck is simple and dexterous, with small turning radius and small weight. It is suitable for ultra-narrow channel operation.
- / The truck has compact and reliable structure. The oil pipeline and line are wrapped in the truck body which is safe and beautiful and convenient for user maintenance.
- / The truck adopts integrated handle design integrating key switch and electric meter which is simple and comfortable for operation.
- / Hand-held lithium battery makes battery changing easier and more convenient.
- / Standard configuration of emergency stop switch and emergency reverse device ensure truck safety.
- / The truck is assembled with power-off braking function. The truck is braked as soon as the handle is loosened or pressed to the bottom.
- / Electromagnetic braking and motor braking are used to ensure the safety of driving.



Electric Pallet Truck Specification

		HANGCHA GROUP CO.,LTD.												
Characteristics	1.1	Manufacturer												
	1.2	Model	CBD15-JL3			CBD18-JL3				CBD20-JL3				
	1.3	Power unit	Electric											
	1.4	Operation	Pedestrian											
	1.5	Rated traction weight	Q (t)	1.5			1.8				2.0			
	1.6	Load centre	c (mm)	600			600				600			
	1.8	Axle centre to fork face	x (mm)	944			944				944			
	1.9	Wheel base	y (mm)	1243			1243				1243			
	Weights	2.1	Service weight with battery	kg	142			142				146		
Wheels, Tyres	3.1	Wheels type	PU											
	3.2	Driving wheel size	Φ×w(mm)	Φ210×70			Φ210×70				Φ210×70			
	3.3	Bearing wheel size	Φ×w(mm)	Φ80×60			Φ80×60				Φ80×60			
	3.5	Wheels, number front/rear (x = driven)	1x/4											
	3.7	Track width	b11 (mm)	400/535			400/535				400/535			
Dimensions	4.4	Lift	h3 (mm)	200			200				200			
	4.9	Overall height(With handle)	h14 (mm)	740/1160			740/1160				740/1160			
	4.15	lowered height	h13 (mm)	85			85				85			
	4.19	Overall length	l1 (mm)	1603			1603				1603			
	4.20	Length to fork face	l2 (mm)	453			453				453			
	4.21	Overall width	b1/ b2 (mm)	550/685			550/685				550/685			
	4.22	Fork dimensions	s/e/l (mm)	50/150/1150			50/150/1150				50/150/1150			
	4.25	Width of forks	bs (mm)	550/685			550/685				550/685			
	4.32	Min.Ground clearance	m2 (mm)	35			35				35			
	4.33	Aisle width with pallet 1000 x 1200 across forks	Ast (mm)	1804			1804				1804			
	4.34	Aisle width with pallet 800 x 1200 along forks	Ast (mm)	1854			1854				1854			
4.35	Min.Turning radius	Wa (mm)	1398			1398				1398				
Perfor- mance	5.1	Travel speed,laden/unladen	(km/h)	4.2/4.5			4.2/4.5				4.2/4.5			
	5.8	Maximum climbing ability, with/without load	(%)	5/10			5/10				5/10			
	5.10	Service brake	Electromagnetic											
Drive	6.1	Drive motor, 60 minute rating	(kw)	0.75			0.75				0.75			
	6.2	Lift motor rating at S3 15%	(kw)	0.8			0.8				0.8			
	6.3	Battery according to DIN 43531/35/36 A,B,C,no	no											
	6.4	Battery voltage/rated capacity	(V/Ah)	24/20	24/30	24/40	24/60	24/20	24/30	24/40	24/60	48/20	48/30	
	6.5	Battery weight (± 5%)	(kg)	6	7.8	10.2	13.2	6	7.8	10.2	13.2	10.2	13.2	
Others	8.1	Type of drive control	DC											
	8.4	Noise level at operator's ear	(dB(A))	≤70										
	10.5	Steering type	Mechanical steering			Mechanical steering				Mechanical steering				

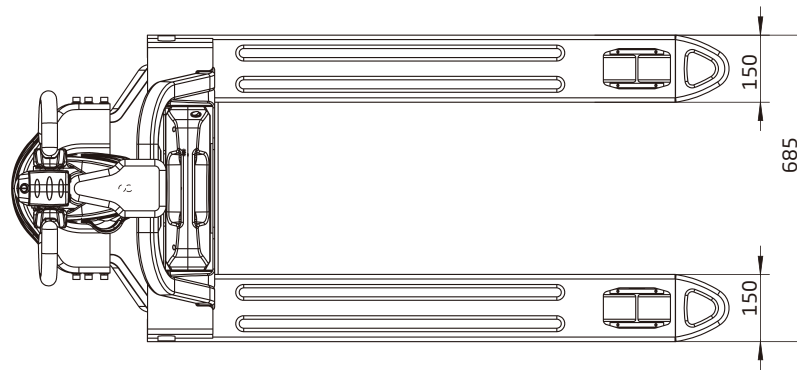
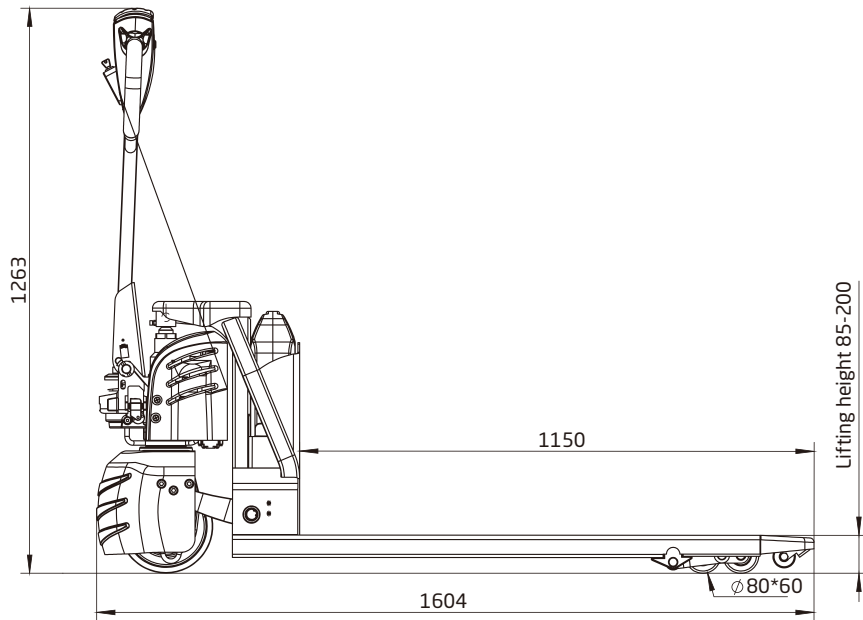

ZHEJIANG HANGCHA IMP. & EXP. CO., LTD.

Factory site: 666 Xiangfu Road,
Hangzhou, Zhejiang, China (311305)

Tel: +86-571-88926735 88926755
Fax: +86-571-88926789 88132890

sales@hcforklift.com
www.hcforklift.com



Follow us on
Facebook



Follow us on
YouTube



Follow us on
WeChat



ISO14001
ISO14001:2015



ISO9001
ISO9001:2015



HANGCHA trucks conform
to the European Safety
Requirements.